

ДВИГАТЕЛИ ДЛЯ АГРОТЕХНИКИ СЕРИЙ TCD 4.1/6.1



Архангельск (8182)63-90-72
Астана (7172)727-132
Астрахань (8512)99-46-04
Барнаул (3852)73-04-60
Белгород (4722)40-23-64
Брянск (4832)59-03-52
Владивосток (423)249-28-31
Волгоград (844)278-03-48
Вологда (8172)26-41-59
Воронеж (473)204-51-73
Екатеринбург (343)384-55-89
Иваново (4932)77-34-06

Ижевск (3412)26-03-58
Иркутск (395)279-98-46
Казань (843)206-01-48
Калининград (4012)72-03-81
Калуга (4842)92-23-67
Кемерово (3842)65-04-62
Киров (8332)68-02-04
Краснодар (861)203-40-90
Красноярск (391)204-63-61
Курск (4712)77-13-04
Липецк (4742)52-20-81

Магнитогорск (3519)55-03-13
Москва (495)268-04-70
Мурманск (8152)59-64-93
Набережные Челны (8552)20-53-41
Нижний Новгород (831)429-08-12
Новокузнецк (3843)20-46-81
Новосибирск (383)227-86-73
Омск (3812)21-46-40
Орел (4862)44-53-42
Оренбург (3532)37-68-04
Пенза (8412)22-31-16

Пермь (342)205-81-47
Ростов-на-Дону (863)308-18-15
Рязань (4912)46-61-64
Самара (846)206-03-16
Санкт-Петербург (812)309-46-40
Саратов (845)249-38-78
Севастополь (8692)22-31-93
Симферополь (3652)67-13-56
Смоленск (4812)29-41-54
Сочи (862)225-72-31
Ставрополь (8652)20-65-13

Сургут (3462)77-98-35
Тверь (4822)63-31-35
Томск (3822)98-41-53
Тула (4872)74-02-29
Тюмень (3452)66-21-18
Ульяновск (8422)24-23-59
Уфа (347)229-48-12
Хабаровск (4212)92-98-04
Челябинск (351)202-03-61
Череповец (8202)49-02-64
Ярославль (4852)69-52-93

Киргизия (996)312-96-26-47

Россия (495)268-04-70

Казахстан (772)734-952-31

<https://deutz.nt-rt.ru> || dze@nt-rt.ru

DEUTZ TCD 4.1/6.1

For agricultural machinery

91–211 kW | 122–283 hp at 2100 min⁻¹/rpm | EU Stage V / US EPA Tier 4



The DEUTZ TCD 4.1 and 6.1 are the compact, water-cooled, 4- and 6-cylinder inline engines for agricultural machinery with a power range from 122 to 283 hp. They already comply with the Stage V exhaust emission requirements. The engines are turbocharged, charge-air cooled, with cooled external exhaust gas recirculation and the 6-cylinder version is also available with two-stage turbocharging.

DISCOVER THE TCD 4.1/6.1

- Water-cooled 4 or 6-cylinder inline engines with turbocharging, charge air cooling and cooled external exhaust gas recirculation. 6-cylinder optionally with two-stage turbocharging for the highest performance requirements.
- Engine and exhaust aftertreatment (EAT) are optimised for highest total system efficiency and thus ensure minimised fuel and total operating cost.
- The powerful DEUTZ Common Rail (DCR[®]) injection system and the electronic engine control (EMR 4) with intelligent link to the drive management ensure optimum engine performance at low fuel consumption.
- 100% power take-off at flywheel and front end.
- The extremely compact engine design with structural oil pan and a customer-oriented modular system of optional add-on parts reduce installation cost and increase the number of applications.
- Best cold starting performance even under extreme conditions.
- 500 h oil change intervals and easy changing of the engine fluids reduce the running cost and increase the availability of the machinery.
- The engines meet the requirements of the EU Stage IV and US EPA Tier 4 with DVERT[®] selective catalytic reduction (SCR) and particulate filter (DPF). Through the use of the DPF they already comply with the EU Stage V emissions standard expected from 2019. A variant without EAT is available as an option for less regulated markets.
- Consistent installation and connection dimensions of the engine facilitate the changeover of existing installations to the next stage of the emission legislation.
- Very smooth running due to optional mass balancing shafts (4 cylinder) guarantees a level of driving comfort.



TECHNICAL DATA

Engine type		TCD 4.1 L4	TCD 6.1 L6	TTCD 6.1 L6
No. of cylinders		4	6	6
Bore/stroke	mm in	101/126 3.98/4.96	101/126 3.98/4.96	101/126 3.98/4.96
Displacement	l cu in	4,1 250	6,1 370	6,1 370
Max. nominal speed	min ⁻¹ rpm	2100	2100	2100

Engine type		TCD 4.1 L4	TCD 6.1 L6	TTCD 6.1 L6
Power output as per ISO 14396 ¹⁾	kW hp	120 160	174 233	211 283
at speed	min ⁻¹ rpm	2100	2100	2100
Max. power	kW hp	126 169	181 243	211 283
at speed	min ⁻¹ rpm	1900	1900	2100
Max. torque	Nm lb/ft	699 516	1072 791	1229 906
at speed	min ⁻¹ rpm	1500	1500	1450
minimum idling speed	min ⁻¹ rpm	800	800	800
Specific fuel consumption ²⁾	g/kWh lb/hph	208 0.34	202 0.33	198 0.33
Weight	kg lb	450 992	676 1490	715 1576

* Based on the proposal by the EU Commission COM (2014) 581 final from 25.09.2014.

1) Power data without deduction of fan power.

2) Best point consumption refers to diesel with a density of 0.835 kg/dm³ at 15°C.

TORQUE CURVES

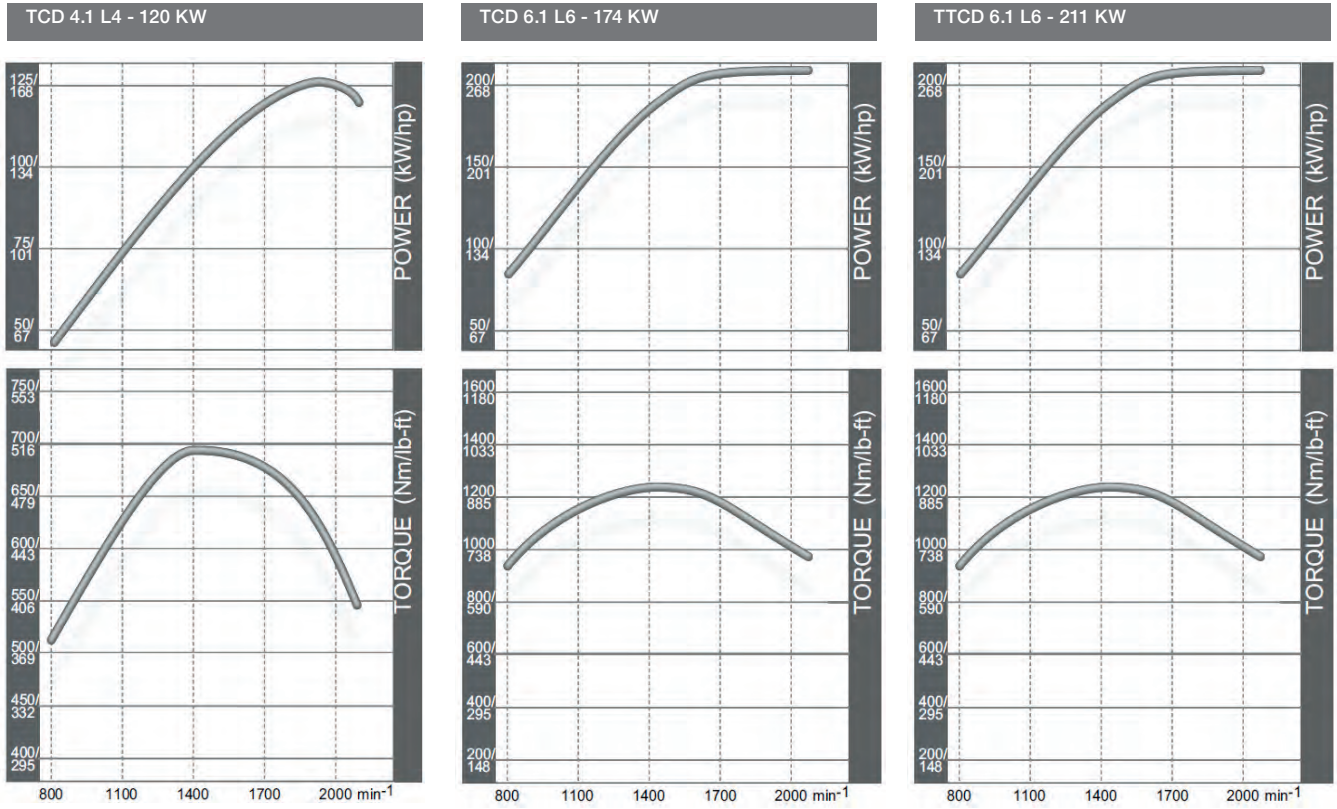

DIMENSIONS

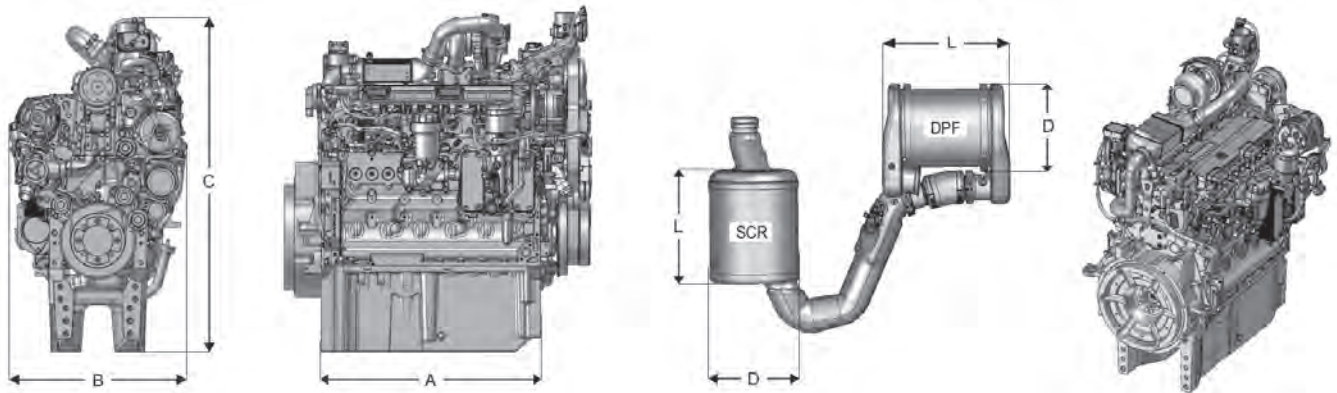

		A		B		C		DPF		SCR		DVERT®-EAT	
		D	L	D	L	D	L	D	L	DOC	DPF		
TCD 4.1 L4	mm in	539 21	607 24	1079 43	278 11	470 19	268 11	385 15	■	■			
TCD 6.1 L6	mm in	767 30	621 24	1205 47	349 14	347 14	268 11	538 21	■	■			
TTCD 6.1 L6	mm in	767 30	639 25	1205 47	349 14	398 16	362 14	367 15	■	■			

■ Standard

Note: The engine dimensions and weights vary depending on the scope of delivery.

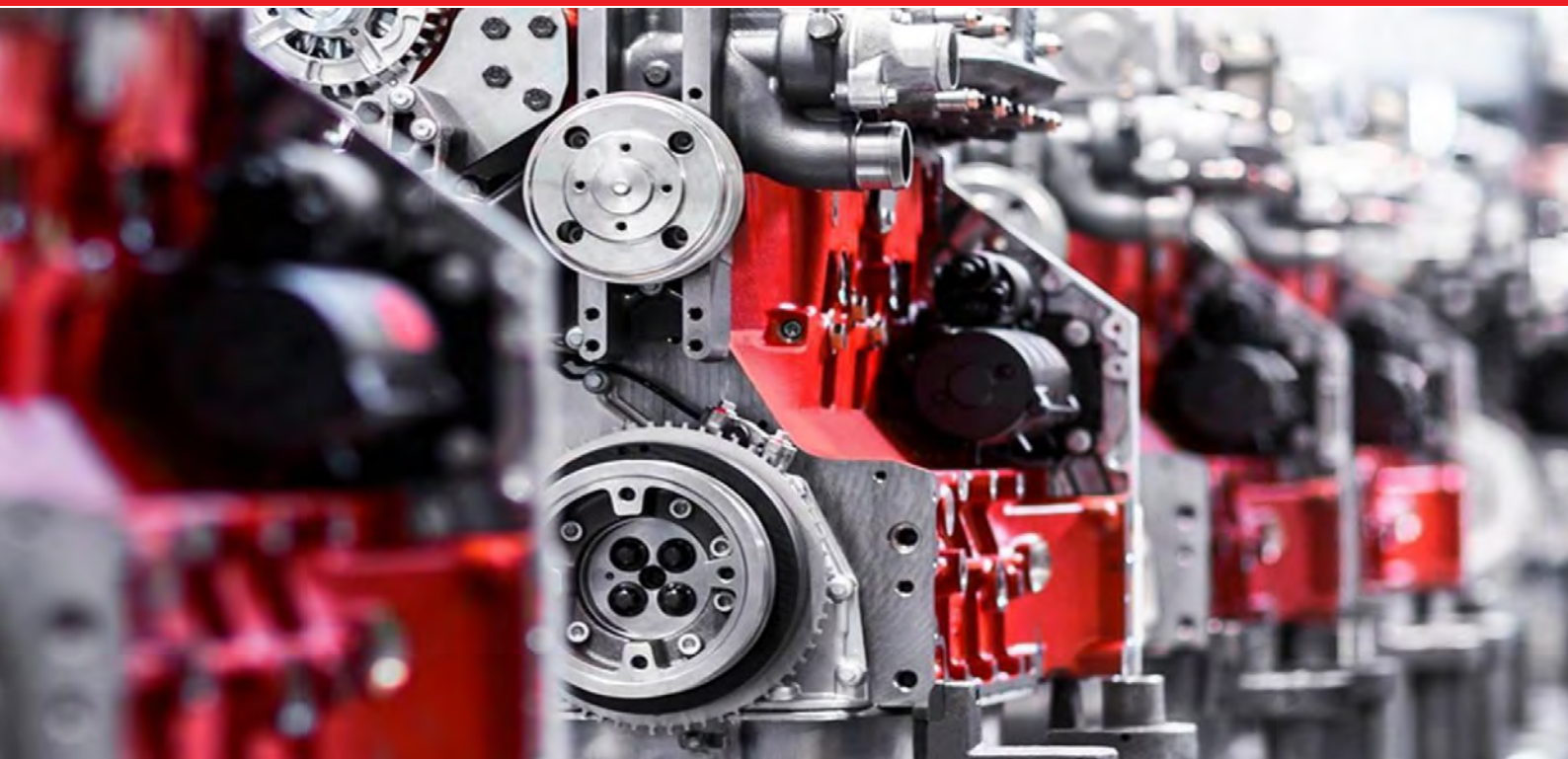

Архангельск (8182)63-90-72
Астана (7172)727-132
Астрахань (8512)99-46-04
Барнаул (3852)73-04-60
Белгород (4722)40-23-64
Брянск (4832)59-03-52
Владивосток (423)249-28-31
Волгоград (844)278-03-48
Вологда (8172)26-41-59
Воронеж (473)204-51-73
Екатеринбург (343)384-55-89
Иваново (4932)77-34-06

Ижевск (3412)26-03-58
Иркутск (395)279-98-46
Казань (843)206-01-48
Калининград (4012)72-03-81
Калуга (4842)92-23-67
Кемерово (3842)65-04-62
Киров (8332)68-02-04
Краснодар (861)203-40-90
Красноярск (391)204-63-61
Курск (4712)77-13-04
Липецк (4742)52-20-81

Магнитогорск (3519)55-03-13
Москва (495)268-04-70
Мурманск (8152)59-64-93
Набережные Челны (8552)20-53-41
Нижний Новгород (831)429-08-12
Новокузнецк (3843)20-46-81
Новосибирск (383)227-86-73
Омск (3812)21-46-40
Орел (4862)44-53-42
Оренбург (3532)37-68-04
Пенза (8412)22-31-16

Пермь (342)205-81-47
Ростов-на-Дону (863)308-18-15
Рязань (4912)46-61-64
Самара (846)206-03-16
Санкт-Петербург (812)309-46-40
Саратов (845)249-38-78
Севастополь (8692)22-31-93
Симферополь (3652)67-13-56
Смоленск (4812)29-41-54
Сочи (862)225-72-31
Ставрополь (8652)20-65-13

Сургут (3462)77-98-35
Тверь (4822)63-31-35
Томск (3822)98-41-53
Тула (4872)74-02-29
Тюмень (3452)66-21-18
Ульяновск (8422)24-23-59
Уфа (347)229-48-12
Хабаровск (4212)92-98-04
Челябинск (351)202-03-61
Череповец (8202)49-02-64
Ярославль (4852)69-52-93

Киргизия (996)312-96-26-47

Россия (495)268-04-70

Казахстан (772)734-952-31

<https://deutz.nt-rt.ru> || dze@nt-rt.ru