

ДВИГАТЕЛИ ДЛЯ АГРОТЕХНИКИ СЕРИИ TCD 2015



Архангельск (8182)63-90-72
Астана (7172)727-132
Астрахань (8512)99-46-04
Барнаул (3852)73-04-60
Белгород (4722)40-23-64
Брянск (4832)59-03-52
Владивосток (423)249-28-31
Волгоград (844)278-03-48
Вологда (8172)26-41-59
Воронеж (473)204-51-73
Екатеринбург (343)384-55-89
Иваново (4932)77-34-06

Ижевск (3412)26-03-58
Иркутск (395)279-98-46
Казань (843)206-01-48
Калининград (4012)72-03-81
Калуга (4842)92-23-67
Кемерово (3842)65-04-62
Киров (8332)68-02-04
Краснодар (861)203-40-90
Красноярск (391)204-63-61
Курск (4712)77-13-04
Липецк (4742)52-20-81

Магнитогорск (3519)55-03-13
Москва (495)268-04-70
Мурманск (8152)59-64-93
Набережные Челны (8552)20-53-41
Нижний Новгород (831)429-08-12
Новокузнецк (3843)20-46-81
Новосибирск (383)227-86-73
Омск (3812)21-46-40
Орел (4862)44-53-42
Оренбург (3532)37-68-04
Пенза (8412)22-31-16

Пермь (342)205-81-47
Ростов-на-Дону (863)308-18-15
Рязань (4912)46-61-64
Самара (846)206-03-16
Санкт-Петербург (812)309-46-40
Саратов (845)249-38-78
Севастополь (8692)22-31-93
Симферополь (3652)67-13-56
Смоленск (4812)29-41-54
Сочи (862)225-72-31
Ставрополь (8652)20-65-13

Сургут (3462)77-98-35
Тверь (4822)63-31-35
Томск (3822)98-41-53
Тула (4872)74-02-29
Тюмень (3452)66-21-18
Ульяновск (8422)24-23-59
Уфа (347)229-48-12
Хабаровск (4212)92-98-04
Челябинск (351)202-03-61
Череповец (8202)49-02-64
Ярославль (4852)69-52-93

Киргизия (996)312-96-26-47

Россия (495)268-04-70

Казахстан (772)734-952-31

<https://deutz.nt-rt.ru> || dze@nt-rt.ru

TCD 2015

For agricultural machinery

240 - 500 kW | 322 - 670 hp at 1900 - 2100 min⁻¹ | rpm

EU Stage IIIA / US EPA Tier 3

- Water-cooled V6 and V8 engines with turbocharging, charge air cooling and four-valve technology.
- Very compact engine design reduces the installation costs.
- Wet cylinder liners, long oil change intervals and easy changing of the engine fluids reduce the running and service costs and increase the availability of the machinery.
- Best cold starting properties even under extreme conditions.



- The V6 is also available as a flat version for extremely compact installations.

- Low noise emissions due to acoustically optimized components with very smooth running and high durability.
- Electronic, solenoid valve-controlled DEUTZ MV-System® (pump-line-nozzle) ensures optimum engine performance at low consumption.
- The robust engine design allows worldwide operation even with high sulphur fuels.

Technical data

Engine type		TCD 2015 V06	TCD 2015 V08
No. of cylinders		6	8
Bore/stroke	mm in	132/145 5.2/5.7	132/145 5.2/5.7
Capacity	l cu in	11.9 726	15.9 970
Compression ratio		17.5:1	17.5:1
Nominal speeds	min ⁻¹ rpm	1800 - 2100	1800 - 2100
Power output ¹⁾		TCD 2015 V06	TCD 2015 V08
Power output as per ISO 14396	kW hp	360 483	500 670
at speed	min ⁻¹ rpm	1900 / 2100	1900 / 2100
Max. torque	Nm lb/ft	2080 1534	2890 2132
at speed	min ⁻¹ rpm	1300	1400
Minimum idling speed	min ⁻¹ rpm	600	600
Specific fuel consumption ²⁾	g/kWh lb/hph	202 0.332	207 0.34
Weight as per DIN 70020 Part 7A ³⁾	kg lb	1020 2249	1245 2745

1) Capacity data without deduction of fan capacity

2) Best full load consumption refers to diesel with a density of 0.835 kg/dm³ at 15°C | 6.96 lb/US gallon at 60°F.

3) Without starter/dynamo, cooler and fluids but with flywheel and flywheel housing.

The data on this data sheet are for information purposes only and are not binding values. The data in the quotation is definitive.

Torque curve

TCD 2015 V 06 - 360 kW|483 hp

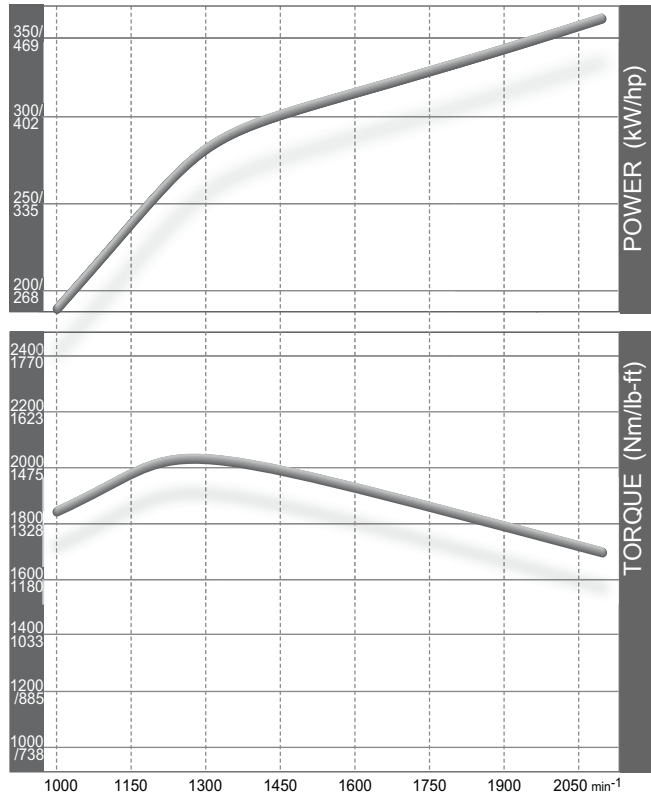

TCD 2015 V 08 - 500 kW|670 hp

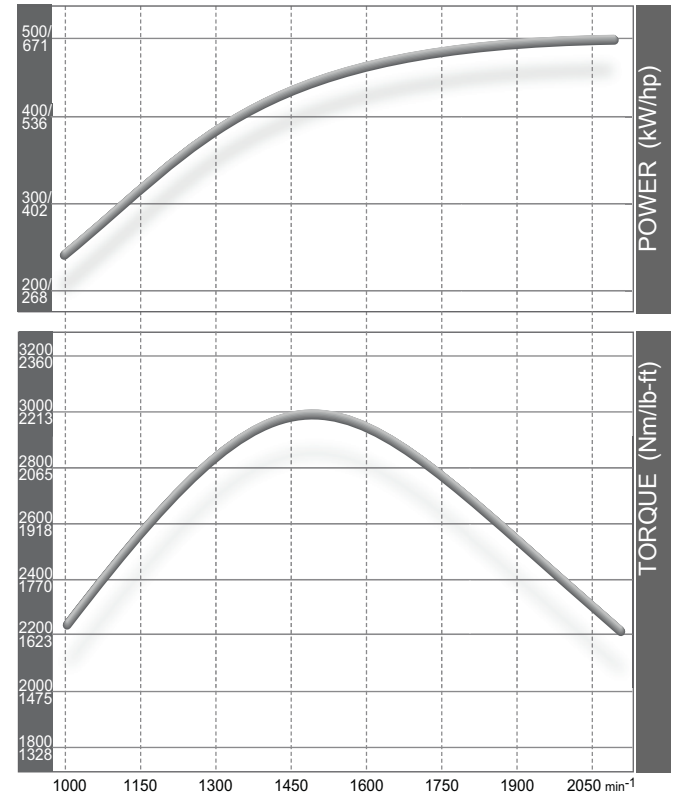

Dimensions

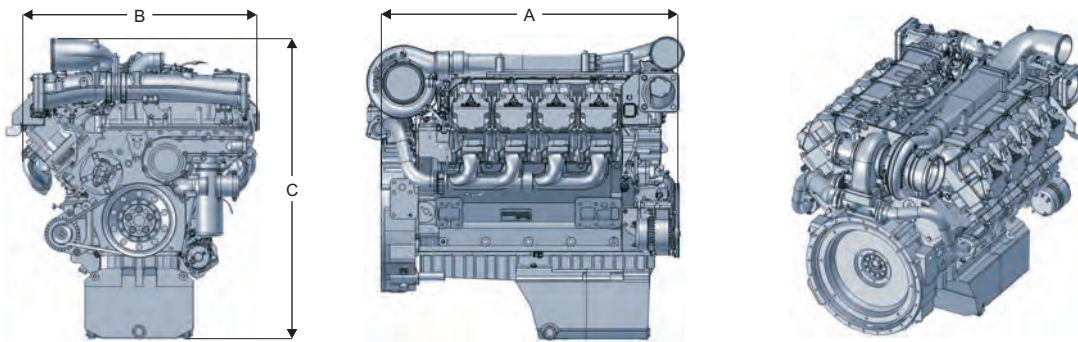

		A	B	C
TCD 2015 V06	mm in	985 38.78	932 36.69	1141 44.88
TCD 2015 V08	mm in	1141 44.88	932 36.69	1172 46.14

Note: The engine dimensions and weights vary depending on the scope of delivery.

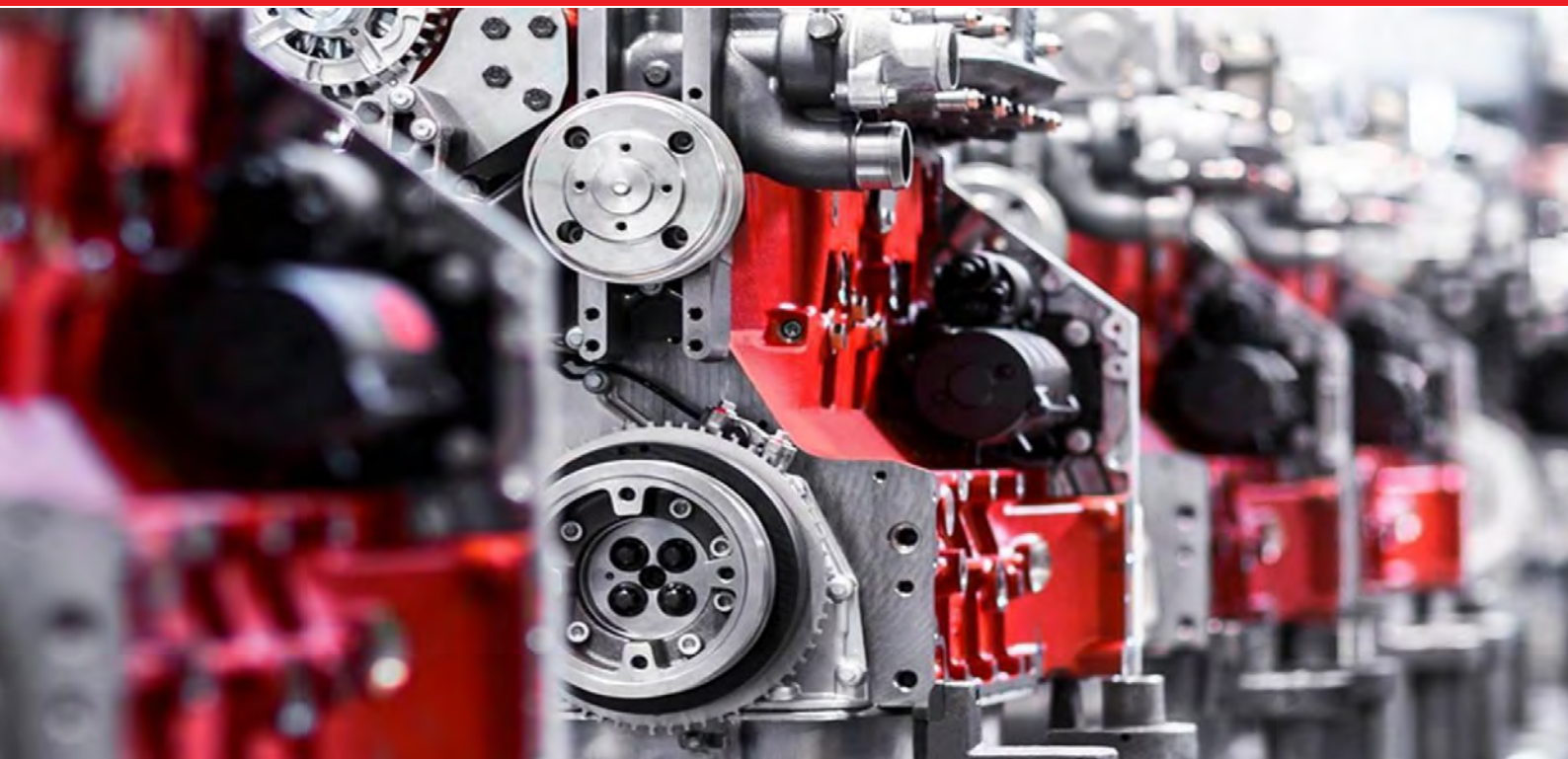

Архангельск (8182)63-90-72
Астана (7172)727-132
Астрахань (8512)99-46-04
Барнаул (3852)73-04-60
Белгород (4722)40-23-64
Брянск (4832)59-03-52
Владивосток (423)249-28-31
Волгоград (844)278-03-48
Вологда (8172)26-41-59
Воронеж (473)204-51-73
Екатеринбург (343)384-55-89
Иваново (4932)77-34-06

Ижевск (3412)26-03-58
Иркутск (395)279-98-46
Казань (843)206-01-48
Калининград (4012)72-03-81
Калуга (4842)92-23-67
Кемерово (3842)65-04-62
Киров (8332)68-02-04
Краснодар (861)203-40-90
Красноярск (391)204-63-61
Курск (4712)77-13-04
Липецк (4742)52-20-81

Магнитогорск (3519)55-03-13
Москва (495)268-04-70
Мурманск (8152)59-64-93
Набережные Челны (8552)20-53-41
Нижний Новгород (831)429-08-12
Новокузнецк (3843)20-46-81
Новосибирск (383)227-86-73
Омск (3812)21-46-40
Орел (4862)44-53-42
Оренбург (3532)37-68-04
Пенза (8412)22-31-16

Пермь (342)205-81-47
Ростов-на-Дону (863)308-18-15
Рязань (4912)46-61-64
Самара (846)206-03-16
Санкт-Петербург (812)309-46-40
Саратов (845)249-38-78
Севастополь (8692)22-31-93
Симферополь (3652)67-13-56
Смоленск (4812)29-41-54
Сочи (862)225-72-31
Ставрополь (8652)20-65-13

Сургут (3462)77-98-35
Тверь (4822)63-31-35
Томск (3822)98-41-53
Тула (4872)74-02-29
Тюмень (3452)66-21-18
Ульяновск (8422)24-23-59
Уфа (347)229-48-12
Хабаровск (4212)92-98-04
Челябинск (351)202-03-61
Череповец (8202)49-02-64
Ярославль (4852)69-52-93

Киргизия (996)312-96-26-47

Россия (495)268-04-70

Казахстан (772)734-952-31

<https://deutz.nt-rt.ru> || dze@nt-rt.ru