

ДВИГАТЕЛИ ДЛЯ АВТОТЕХНИКИ СЕРИИ TCD 2013



Архангельск (8182)63-90-72
Астана (7172)727-132
Астрахань (8512)99-46-04
Барнаул (3852)73-04-60
Белгород (4722)40-23-64
Брянск (4832)59-03-52
Владивосток (423)249-28-31
Волгоград (844)278-03-48
Вологда (8172)26-41-59
Воронеж (473)204-51-73
Екатеринбург (343)384-55-89
Иваново (4932)77-34-06

Ижевск (3412)26-03-58
Иркутск (395)279-98-46
Казань (843)206-01-48
Калининград (4012)72-03-81
Калуга (4842)92-23-67
Кемерово (3842)65-04-62
Киров (8332)68-02-04
Краснодар (861)203-40-90
Красноярск (391)204-63-61
Курск (4712)77-13-04
Липецк (4742)52-20-81

Магнитогорск (3519)55-03-13
Москва (495)268-04-70
Мурманск (8152)59-64-93
Набережные Челны (8552)20-53-41
Нижний Новгород (831)429-08-12
Новокузнецк (3843)20-46-81
Новосибирск (383)227-86-73
Омск (3812)21-46-40
Орел (4862)44-53-42
Оренбург (3532)37-68-04
Пенза (8412)22-31-16

Пермь (342)205-81-47
Ростов-на-Дону (863)308-18-15
Рязань (4912)46-61-64
Самара (846)206-03-16
Санкт-Петербург (812)309-46-40
Саратов (845)249-38-78
Севастополь (8692)22-31-93
Симферополь (3652)67-13-56
Смоленск (4812)29-41-54
Сочи (862)225-72-31
Ставрополь (8652)20-65-13

Сургут (3462)77-98-35
Тверь (4822)63-31-35
Томск (3822)98-41-53
Тула (4872)74-02-29
Тюмень (3452)66-21-18
Ульяновск (8422)24-23-59
Уфа (347)229-48-12
Хабаровск (4212)92-98-04
Челябинск (351)202-03-61
Череповец (8202)49-02-64
Ярославль (4852)69-52-93

Киргизия (996)312-96-26-47

Россия (495)268-04-70

Казахстан (772)734-952-31

<https://deutz.nt-rt.ru> || dze@nt-rt.ru

TCD 2013

For trucks and buses

118 - 247 kW/160 - 335 PS at 2100/2300 min⁻¹

EURO III - V EEV

- Water-cooled 4 or 6-cylinder inline engines with turbocharging and charge air cooling.
- The powerful DEUTZ Common Rail (DCR[®]) injection system and the electronic engine control with intelligent link to the drive management ensure optimum engine performance at low fuel consumption.
- The engines meet the requirements of exhaust classes EURO IV and V by the use of selective catalytic reduction (SCR). EURO III is achieved without exhaust gas aftertreatment.
- Best cold starting performance even under extreme conditions.



- Oil change intervals of up to 50,000 km and easy changing of the engine fluids reduce the running costs and increase the availability of the machinery.
- Integrated engine brake optional in 6-cylinder engines.

- Unchanged installation and connection dimensions of the engine simplify the installation of engines of different exhaust classes.
- Easy, inexpensive installation due to minimum weight and small installation space.
- 100% power takeoff on the flywheel and at the front and side gear wheel-driven PTO drive with up to 190 Nm, additional optional powerful PTO with up to 600 Nm.
- Engines for bus applications as 6-cylinder TCD 2013 L6 4V.
- The TCD 2013 meets the requirements of EURO III - V and EEV.

Technical data

Engine type		TCD 2013 L4 4V	TCD 2013 L6 4V
No. of cylinders		4	6
Bore/stroke	mm	108 / 130	108 / 130
Displacement	l	4,8	7,2
Nominal speeds	min ⁻¹	2300	2100 / 2300

Dimensions

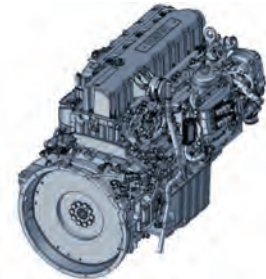
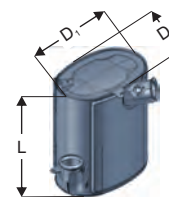
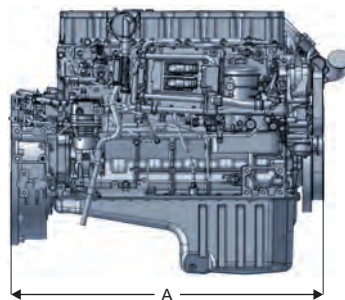
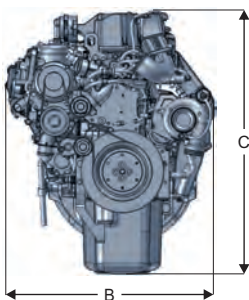

		A	B	C	D ₁	D ₂	L
TCD 2013 L4 4V	mm	894	754	911	296	296	895
TCD 2013 L6 4V	mm	1158	787	983	540	370	640

Note: The engine dimensions and weights vary depending on the scope of delivery.

TCD 2013 L4 4V Truck

Truck		TCD 2013 L4 4V				
Exhaust class		EURO III		EURO IV		
Power output as per ISO 1585	kW/PS	140/190	158/215	118/160	140/190	158/215
at speed	min ⁻¹	2300		2300		
Max. torque	Nm	680	800	580	680	800
at speed	min ⁻¹	1200 - 1700		1200 - 1700		
Minimum idling speed	min ⁻¹	700		700		
Specific fuel consumption ¹⁾	g/kWh	198	201	201	203	205
Weight as per DIN 70020 Part 7A ²⁾	kg	490	490	490	490	490

Truck		TCD 2013 L4 4V	
Exhaust class		EURO V	
Power output as per ISO 1585	kW/PS	136/185	161/220
at speed	min ⁻¹	2300	
Max. torque	Nm	663	816
at speed	min ⁻¹	1200 - 1700	
Minimum idling speed	min ⁻¹	700	
Specific fuel consumption ¹⁾	g/kWh	199	200
Weight as per DIN 70020 Part 7A ²⁾	kg	490	490

1) Best full load consumption refers to diesel with a density of 0.835 kg/dm³ at 15°C | 6.96 lb/US gallon at 60°F.

2) Without starter/alternator, cooler and fluids but with flywheel and flywheel housing.

The data on this data sheet are for information purposes only and are not binding values. The data in the quotation is definitive.

Torque curve

TCD 2013 L4 4V, EURO III/IV

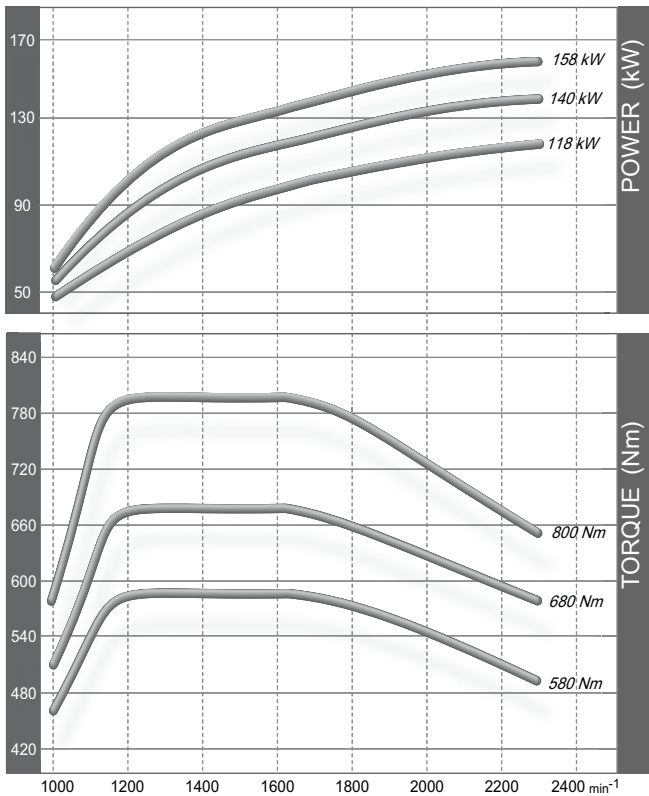

TCD 2013 L4 4V, EURO V

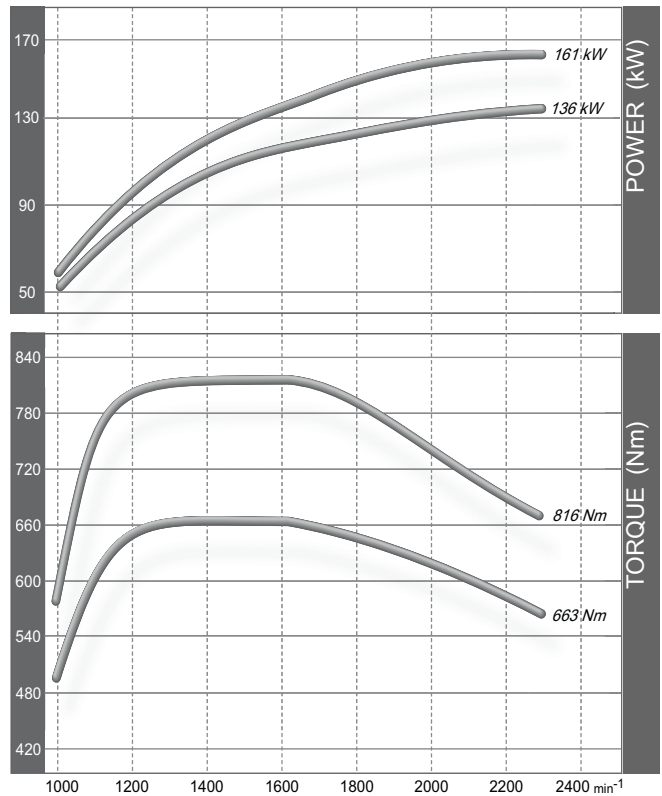

TCD 2013 L6 4V Truck

Truck		TCD 2013 L6 4V					
Exhaust class		EURO III			EURO IV		
Power output as per ISO 1585	kW/PS	177/240	206/280	235/320	177/240	206/280	235/320
at speed	min ⁻¹	2300			2300		
Max. torque	Nm	920	1050	1200	920	1050	1200
at speed	min ⁻¹	1200 - 1700			1200 - 1700		
Minimum idling speed	min ⁻¹	600			600		
Specific fuel consumption ¹⁾	g/kWh	201	197	200	196	197	199
Weight as per DIN 70020 Part 7A ²⁾	kg	650	650	650	650	650	650

Truck		TCD 2013 L6 4V				
Exhaust class		EURO V				
Power output as per ISO 1585	kW/PS	181/245	195/265	217/295	225/305	247/335
at speed	min ⁻¹	2300				
Max. torque	Nm	938	1010	1071	1153	1306
at speed	min ⁻¹	1200 - 1800			1200 - 1700	
Minimum idling speed	min ⁻¹	600				
Specific fuel consumption ¹⁾	g/kWh	204	207	200	200	200
Weight as per DIN 70020 Part 7A ²⁾	kg	650	650	650	650	650

1) Best full load consumption refers to diesel with a density of 0.835 kg/dm³ at 15°C | 6.96 lb/US gallon at 60°F.

2) Without starter/alternator, cooler and fluids but with flywheel and flywheel housing.

The data on this data sheet are for information purposes only and are not binding values. The data in the quotation is definitive.

Torque curve

TCD 2013 L6 4V, EURO III/IV

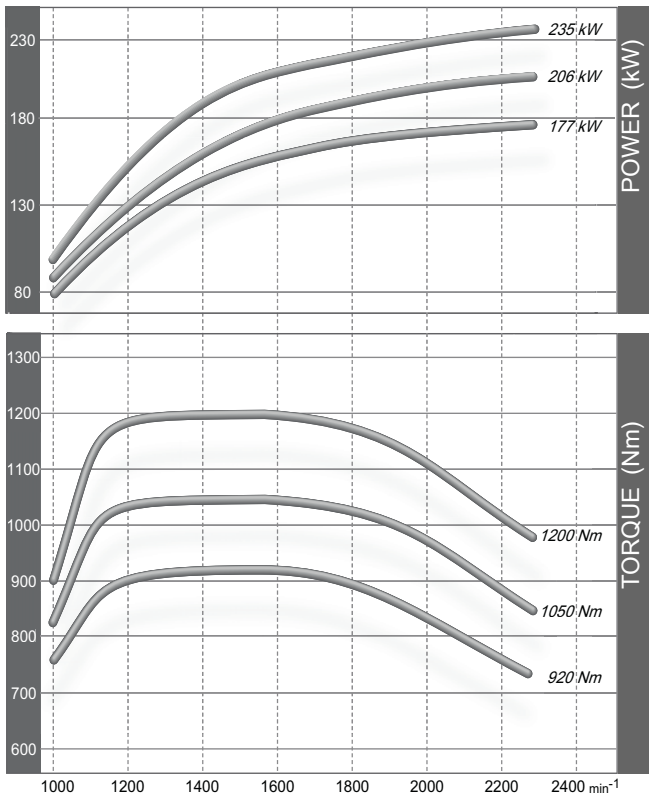

TCD 2013 L6 4V, EURO V

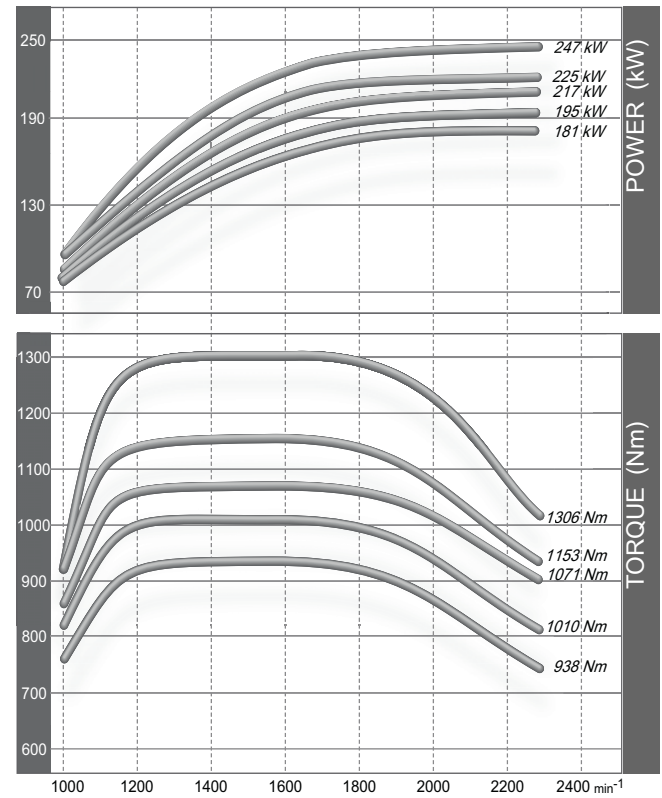

TCD 2013 L6 4V Bus

Bus		TCD 2013 L6 4V		
Exhaust class		EURO III	EURO IV	EURO V EEV
Power output as per ISO 1585	kW/PS	213/290	213/290	213/290
at speed	min ⁻¹	2100	2100	2100
Max. torque	Nm	1200	1200	1200
at speed	min ⁻¹	1050 - 1600	1050 - 1600	1050 - 1650
Minimum idling speed	min ⁻¹	600	600	600
Specific fuel consumption ¹⁾	g/kWh	197	194	204
Weight as per DIN 70020 Part 7A ²⁾	kg	650	650	650

1) Best full load consumption refers to diesel with a density of 0.835 kg/dm³ at 15°C | 6.96 lb/US gallon at 60°F.

2) Without starter/alternator, cooler and fluids but with flywheel and flywheel housing.

The data on this data sheet are for information purposes only and are not binding values. The data in the quotation is definitive.

Torque curve

TCD 2013 L6 4V, EURO III/IV/V EEV

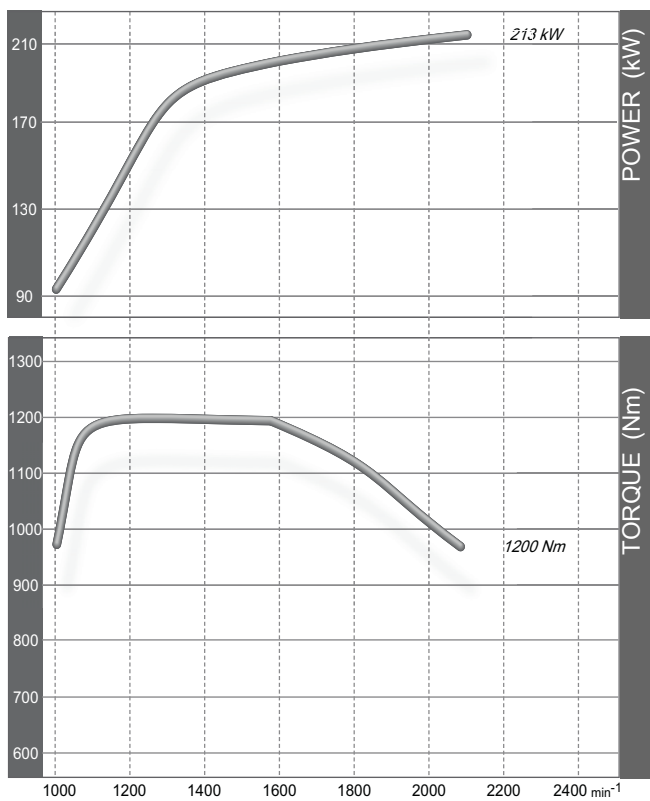

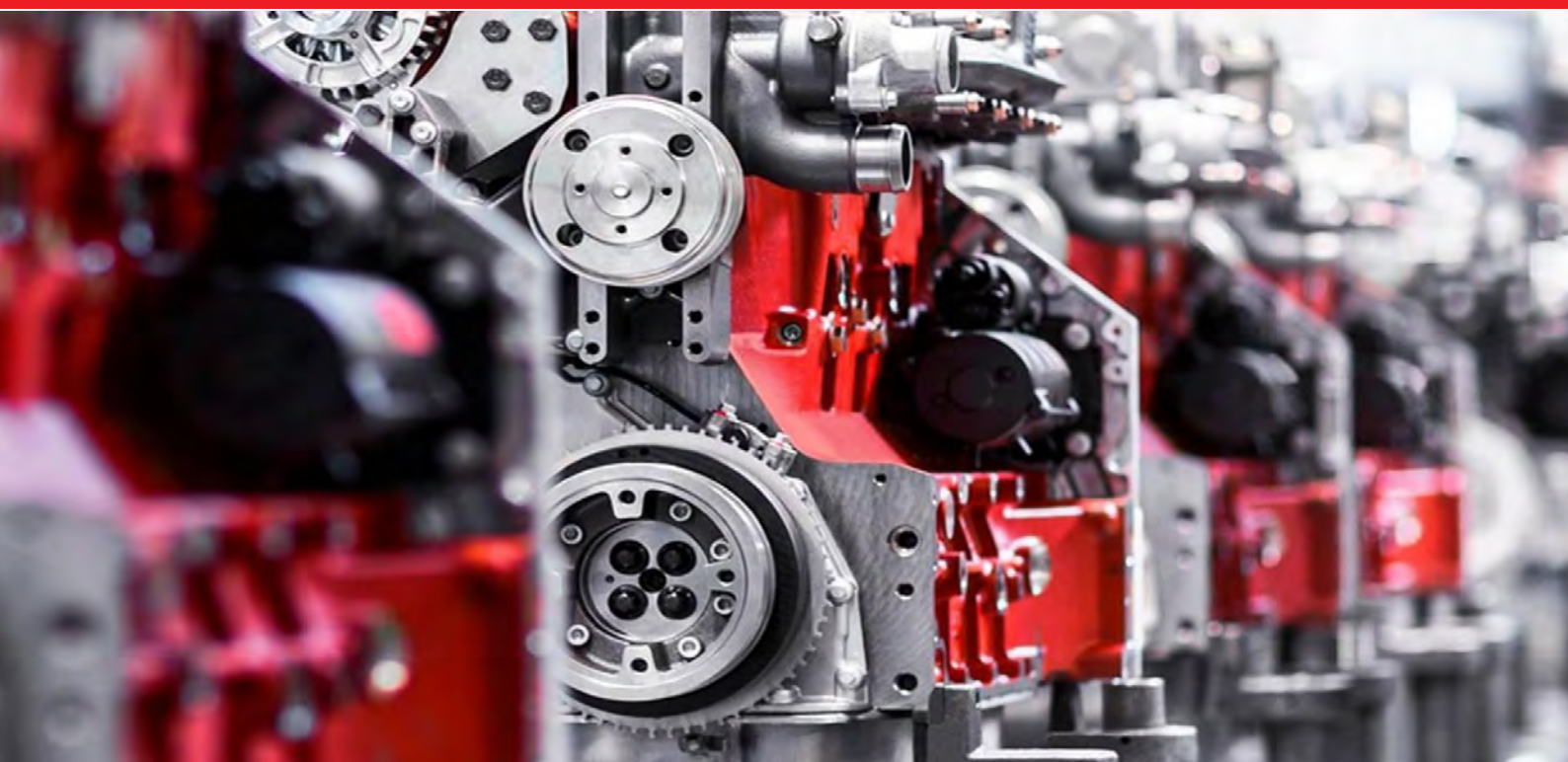

Архангельск (8182)63-90-72
Астана (7172)727-132
Астрахань (8512)99-46-04
Барнаул (3852)73-04-60
Белгород (4722)40-23-64
Брянск (4832)59-03-52
Владивосток (423)249-28-31
Волгоград (844)278-03-48
Вологда (8172)26-41-59
Воронеж (473)204-51-73
Екатеринбург (343)384-55-89
Иваново (4932)77-34-06

Ижевск (3412)26-03-58
Иркутск (395)279-98-46
Казань (843)206-01-48
Калининград (4012)72-03-81
Калуга (4842)92-23-67
Кемерово (3842)65-04-62
Киров (8332)68-02-04
Краснодар (861)203-40-90
Красноярск (391)204-63-61
Курск (4712)77-13-04
Липецк (4742)52-20-81

Магнитогорск (3519)55-03-13
Москва (495)268-04-70
Мурманск (8152)59-64-93
Набережные Челны (8552)20-53-41
Нижний Новгород (831)429-08-12
Новокузнецк (3843)20-46-81
Новосибирск (383)227-86-73
Омск (3812)21-46-40
Орел (4862)44-53-42
Оренбург (3532)37-68-04
Пенза (8412)22-31-16

Пермь (342)205-81-47
Ростов-на-Дону (863)308-18-15
Рязань (4912)46-61-64
Самара (846)206-03-16
Санкт-Петербург (812)309-46-40
Саратов (845)249-38-78
Севастополь (8692)22-31-93
Симферополь (3652)67-13-56
Смоленск (4812)29-41-54
Сочи (862)225-72-31
Ставрополь (8652)20-65-13

Сургут (3462)77-98-35
Тверь (4822)63-31-35
Томск (3822)98-41-53
Тула (4872)74-02-29
Тюмень (3452)66-21-18
Ульяновск (8422)24-23-59
Уфа (347)229-48-12
Хабаровск (4212)92-98-04
Челябинск (351)202-03-61
Череповец (8202)49-02-64
Ярославль (4852)69-52-93

Киргизия (996)312-96-26-47

Россия (495)268-04-70

Казахстан (772)734-952-31

<https://deutz.nt-rt.ru> || dze@nt-rt.ru