

ДВИГАТЕЛИ ДЛЯ АГРОТЕХНИКИ СЕРИИ TCD 2012



Архангельск (8182)63-90-72
Астана (7172)727-132
Астрахань (8512)99-46-04
Барнаул (3852)73-04-60
Белгород (4722)40-23-64
Брянск (4832)59-03-52
Владивосток (423)249-28-31
Волгоград (844)278-03-48
Вологда (8172)26-41-59
Воронеж (473)204-51-73
Екатеринбург (343)384-55-89
Иваново (4932)77-34-06

Ижевск (3412)26-03-58
Иркутск (395)279-98-46
Казань (843)206-01-48
Калининград (4012)72-03-81
Калуга (4842)92-23-67
Кемерово (3842)65-04-62
Киров (8332)68-02-04
Краснодар (861)203-40-90
Красноярск (391)204-63-61
Курск (4712)77-13-04
Липецк (4742)52-20-81

Магнитогорск (3519)55-03-13
Москва (495)268-04-70
Мурманск (8152)59-64-93
Набережные Челны (8552)20-53-41
Нижний Новгород (831)429-08-12
Новокузнецк (3843)20-46-81
Новосибирск (383)227-86-73
Омск (3812)21-46-40
Орел (4862)44-53-42
Оренбург (3532)37-68-04
Пенза (8412)22-31-16

Пермь (342)205-81-47
Ростов-на-Дону (863)308-18-15
Рязань (4912)46-61-64
Самара (846)206-03-16
Санкт-Петербург (812)309-46-40
Саратов (845)249-38-78
Севастополь (8692)22-31-93
Симферополь (3652)67-13-56
Смоленск (4812)29-41-54
Сочи (862)225-72-31
Ставрополь (8652)20-65-13

Сургут (3462)77-98-35
Тверь (4822)63-31-35
Томск (3822)98-41-53
Тула (4872)74-02-29
Тюмень (3452)66-21-18
Ульяновск (8422)24-23-59
Уфа (347)229-48-12
Хабаровск (4212)92-98-04
Челябинск (351)202-03-61
Череповец (8202)49-02-64
Ярославль (4852)69-52-93

Киргизия (996)312-96-26-47

Россия (495)268-04-70

Казахстан (772)734-952-31

<https://deutz.nt-rt.ru> || dze@nt-rt.ru

TCD 2012

For agricultural machinery

103 - 155 kW | 138 - 208 hp at 2400 min⁻¹ | rpm

EU Stage IIIA / US EPA Tier 3

- Water-cooled 4 and 6-cylinder inline engines with turbocharging and charge air cooling
- The extremely compact engine design with structural oil pan and a customer-oriented, modular system of optional add-on parts reduce the installation costs and increase the number of applications.
- The powerful DEUTZ Common-Rail (DCR[®]) injection system and the electronic engine control (EMR 3) with intelligent link to the drive management ensure optimum engine performance at low fuel consumption.



- The 4-cylinder is also available with a mechanical injection system in the power range up to 88 kW.

- Low noise emissions due to acoustically optimized components with very smooth running and high durability.
- Long oil change intervals and easy changing of the engine fluids reduce the running costs and increase the availability of the machinery.
- 100% power take-off at flywheel and front end.
- Best cold starting performance even under extreme conditions.
- The engines meet the requirements of the EU Stage IIIA and US EPA Tier 3.

Technical data

Engine type		TCD 2012 L4	TCD 2012 L6
No. of cylinders		4	6
Bore/stroke	mm in	101 / 126 4.0 / 5.0	101 / 126 4.0 / 5.0
Displacement	l cu in	4.04 247	6.06 370
Max. nominal speed	min ⁻¹ rpm	2400	2400

Engine type		TCD 2012 L4	TCD 2012 L6
Power output as per ISO 14396 ¹⁾	kW hp	103 138	155 208
at speed	min ⁻¹ rpm	2400	2400
Max. torque	Nm lb/ft	520 384	810 ⁴⁾ 597
at speed	min ⁻¹ rpm	1600	1600
Minimum idling speed	min ⁻¹ rpm	650	650
Specific fuel consumption ²⁾	g/kWh lb/hph	215 0.35	215 0.35
Weight as per DIN 70020 Part 7A ³⁾	kg lb	400 882	510 1124

1) Power data without deduction of fan power.

2) Best point consumption refers to diesel with a density of 0.835 kg/dm³ at 15°C.

3) Without starter/alternator, cooler and fluids but with flywheel and flywheel housing.

4) 850 Nm | 627 lb-ft with switched internal EGR (exhaust gas return)

The data on this data sheet are for information purposes only and are not binding values. The data in the quotation is definitive.

Torque curve

TCD 2012 L4 - 103 kW|138 hp

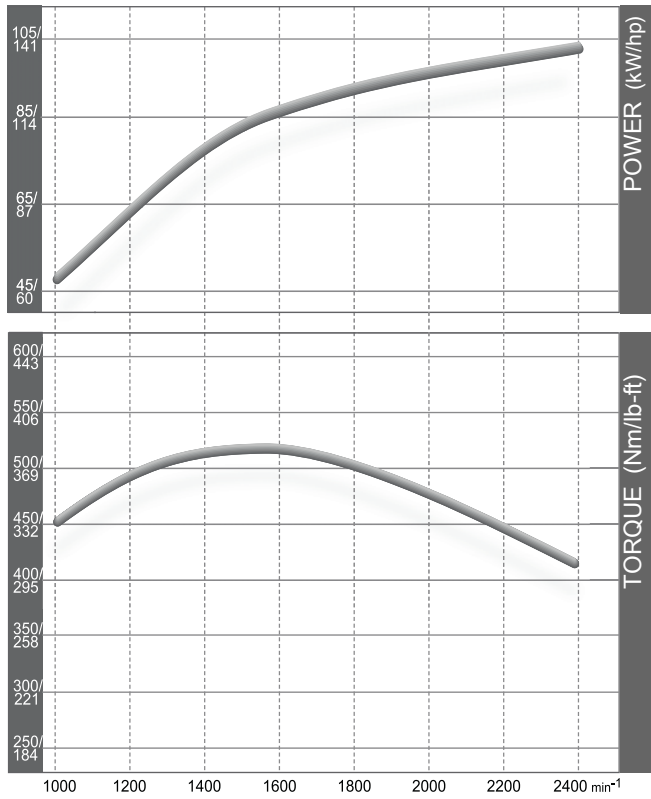

TCD 2012 L6 - 155 kW|208 hp

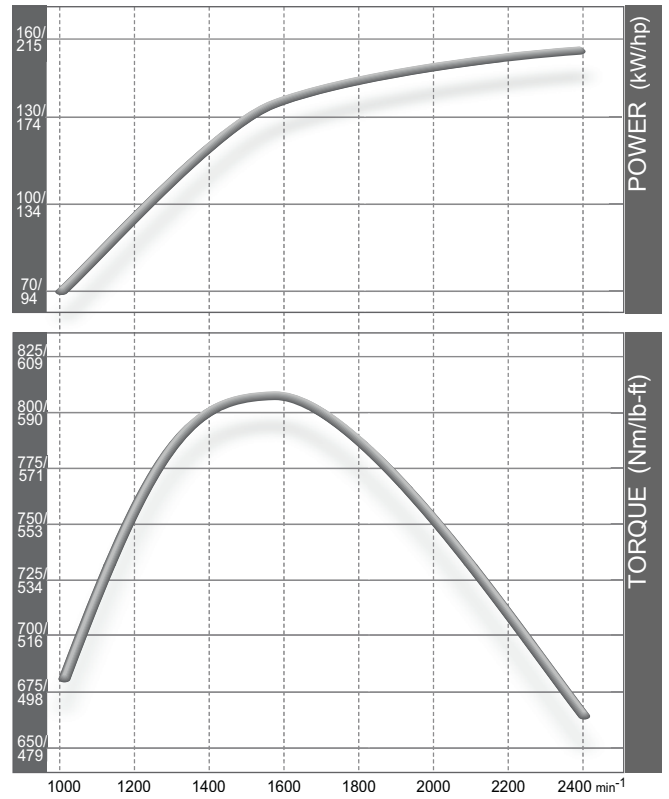

Dimensions

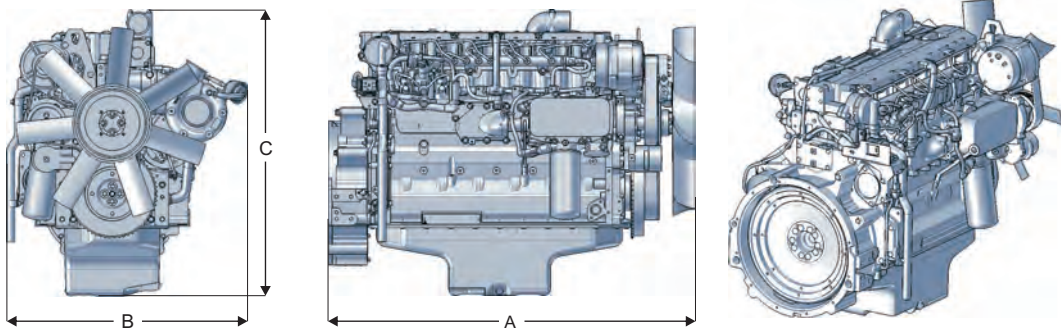

		A	B	C
TCD 2012 L4	mm in	783 30.8	629 24.8	812 32.0
TCD 2012 L6	mm in	1041 41.0	667 26.3	897 35.3

Note: The engine dimensions and weights vary depending on the scope of delivery.

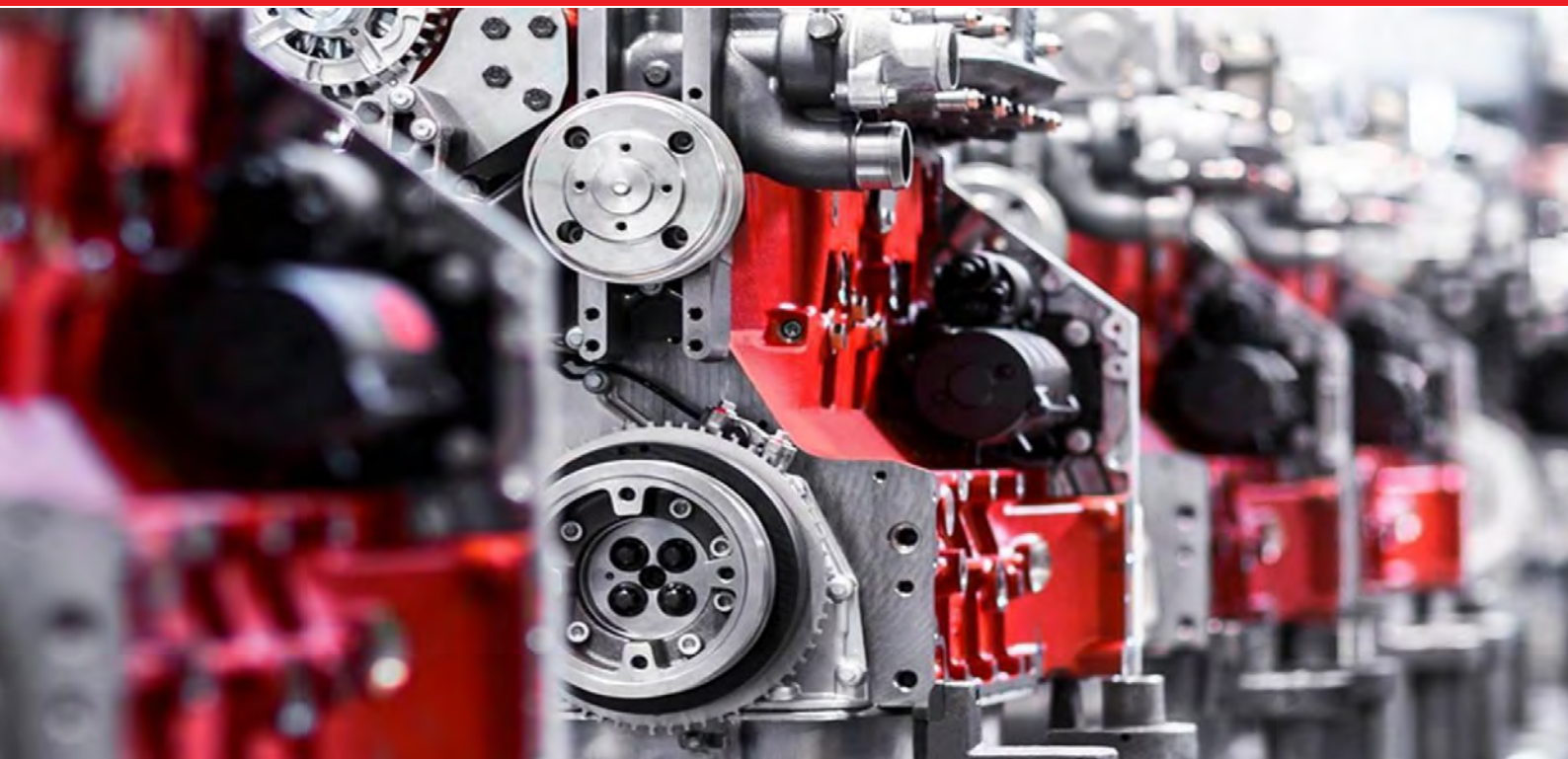

Архангельск (8182)63-90-72
Астана (7172)727-132
Астрахань (8512)99-46-04
Барнаул (3852)73-04-60
Белгород (4722)40-23-64
Брянск (4832)59-03-52
Владивосток (423)249-28-31
Волгоград (844)278-03-48
Вологда (8172)26-41-59
Воронеж (473)204-51-73
Екатеринбург (343)384-55-89
Иваново (4932)77-34-06

Ижевск (3412)26-03-58
Иркутск (395)279-98-46
Казань (843)206-01-48
Калининград (4012)72-03-81
Калуга (4842)92-23-67
Кемерово (3842)65-04-62
Киров (8332)68-02-04
Краснодар (861)203-40-90
Красноярск (391)204-63-61
Курск (4712)77-13-04
Липецк (4742)52-20-81

Магнитогорск (3519)55-03-13
Москва (495)268-04-70
Мурманск (8152)59-64-93
Набережные Челны (8552)20-53-41
Нижний Новгород (831)429-08-12
Новокузнецк (3843)20-46-81
Новосибирск (383)227-86-73
Омск (3812)21-46-40
Орел (4862)44-53-42
Оренбург (3532)37-68-04
Пенза (8412)22-31-16

Пермь (342)205-81-47
Ростов-на-Дону (863)308-18-15
Рязань (4912)46-61-64
Самара (846)206-03-16
Санкт-Петербург (812)309-46-40
Саратов (845)249-38-78
Севастополь (8692)22-31-93
Симферополь (3652)67-13-56
Смоленск (4812)29-41-54
Сочи (862)225-72-31
Ставрополь (8652)20-65-13

Сургут (3462)77-98-35
Тверь (4822)63-31-35
Томск (3822)98-41-53
Тула (4872)74-02-29
Тюмень (3452)66-21-18
Ульяновск (8422)24-23-59
Уфа (347)229-48-12
Хабаровск (4212)92-98-04
Челябинск (351)202-03-61
Череповец (8202)49-02-64
Ярославль (4852)69-52-93

Киргизия (996)312-96-26-47

Россия (495)268-04-70

Казахстан (772)734-952-31

<https://deutz.nt-rt.ru> || dze@nt-rt.ru