

СТАЦИОНАРНЫЕ ДВИГАТЕЛИ СЕРИИ FL 912



Архангельск (8182)63-90-72
Астана (7172)727-132
Астрахань (8512)99-46-04
Барнаул (3852)73-04-60
Белгород (4722)40-23-64
Брянск (4832)59-03-52
Владивосток (423)249-28-31
Волгоград (844)278-03-48
Вологда (8172)26-41-59
Воронеж (473)204-51-73
Екатеринбург (343)384-55-89
Иваново (4932)77-34-06

Ижевск (3412)26-03-58
Иркутск (395)279-98-46
Казань (843)206-01-48
Калининград (4012)72-03-81
Калуга (4842)92-23-67
Кемерово (3842)65-04-62
Киров (8332)68-02-04
Краснодар (861)203-40-90
Красноярск (391)204-63-61
Курск (4712)77-13-04
Липецк (4742)52-20-81

Магнитогорск (3519)55-03-13
Москва (495)268-04-70
Мурманск (8152)59-64-93
Набережные Челны (8552)20-53-41
Нижний Новгород (831)429-08-12
Новокузнецк (3843)20-46-81
Новосибирск (383)227-86-73
Омск (3812)21-46-40
Орел (4862)44-53-42
Оренбург (3532)37-68-04
Пенза (8412)22-31-16

Пермь (342)205-81-47
Ростов-на-Дону (863)308-18-15
Рязань (4912)46-61-64
Самара (846)206-03-16
Санкт-Петербург (812)309-46-40
Саратов (845)249-38-78
Севастополь (8692)22-31-93
Симферополь (3652)67-13-56
Смоленск (4812)29-41-54
Сочи (862)225-72-31
Ставрополь (8652)20-65-13

Сургут (3462)77-98-35
Тверь (4822)63-31-35
Томск (3822)98-41-53
Тула (4872)74-02-29
Тюмень (3452)66-21-18
Ульяновск (8422)24-23-59
Уфа (347)229-48-12
Хабаровск (4212)92-98-04
Челябинск (351)202-03-61
Череповец (8202)49-02-64
Ярославль (4852)69-52-93

Киргизия (996)312-96-26-47

Россия (495)268-04-70

Казахстан (772)734-952-31

<https://deutz.nt-rt.ru> || dze@nt-rt.ru

FL 912

for stationary sets

26.5 - 67 kW | 36 - 90 hp at 1500/1800 min⁻¹ | rpm
for markets without emission regulation

- Air-cooled 3 to 6-cylinder naturally aspirated engines in inline arrangement.
- Low noise emissions due to acoustically optimized components with very smooth running and high durability.
- Easy, inexpensive installation due to minimum weight and small installation space.
- Best cold starting performance even under extreme conditions.



- The robust engine design allows worldwide operation even with high sulphur fuels.
- Highly efficient injection and combustion system ensures optimum engine performance at low consumption.
- A very good load response ensures an immediate power supply.

Technical data

Engine type		F3L 912	F4L 912	F6L 912
No. of cylinders		3	4	6
Bore/stroke	mm in	102/132 4.0/5.2	102/132 4.0/5.2	102/132 4.0/5.2
Displacement	l cu in	3.2 197	4.3 263	6.5 395
Weight (incl. cooler and fan)	kg lb	277 611	307 677	430 948
Governing standard ¹⁾		G2	G2	G2

50 Hz / 1500 min⁻¹

Power		F3L 912	F4L 912	F6L 912
Continuous Power (COP) ²⁾	kW hp	26.5 35.5	35.0 46.9	53.0 71.1
Prime Power (PRP) ³⁾	kW hp	27.5 36.9	37.0 49.6	55.0 73.8
Limited Time Power (LTP) ⁴⁾	kW hp	28.0 37.5	38.0 51.0	56.0 75.1
Fan power consumption	kW hp	0.5 0.7	0.5 0.7	1.0 1.3
Typical Generator Output COP ⁵⁾	kVA	29	39	59
Typical Generator Output PRP ⁵⁾	kVA	30	41	61
Typical Generator Output LTP ⁵⁾	kVA	31	42	62

60 Hz / 1800 min⁻¹

Power		F3L 912	F4L 912	F6L 912
Continuous Power (COP) ²⁾	kW hp	31.0 41.6	42.0 56.3	63.0 84.5
Prime Power (PRP) ³⁾	kW hp	32.0 42.9	43.5 58.3	65.5 87.8
Limited Time Power (LTP) ⁴⁾	kW hp	33.0 44.3	44.5 59.7	67.0 89.8
Fan power consumption	kW hp	1.0 1.3	1.0 1.3	1.5 2.0
Typical Generator Output COP ⁵⁾	kWe	27	37	55
Typical Generator Output PRP ⁵⁾	kWe	28	38	58
Typical Generator Output LTP ⁵⁾	kWe	28	39	59

50 Hz / 1500 min⁻¹

Fuel Consumption (PRP) ⁶⁾		F3L 912	F4L 912	F6L 912
Fuel consumption 25% load	g/kWh lb/hph	360 0.59	360 0.59	360 0.59
Fuel consumption 50% load	g/kWh lb/hph	238 0.39	238 0.39	238 0.39
Fuel consumption 75% load	g/kWh lb/hph	219 0.36	219 0.36	219 0.36
Fuel consumption 100% load	g/kWh lb/hph	218 0.36	218 0.36	218 0.36

Inlet & exhaust data		F3L 912	F4L 912	F6L 912
max. intake depression	mbar psi	10 0.15	10 0.15	10 0.15
Combustion air volume	m ³ /h cfm	131 77	174 102	262 154
max. exhaust gas temperature	°C °F	500 932	500 932	500 932
Exhaust gas flow	m ³ /h cfm	358 211	476 280	715 421

60 Hz / 1800 min⁻¹

Fuel Consumption (PRP) ⁶⁾		F3L 912	F4L 912	F6L 912
Fuel consumption 25% load	g/kWh lb/hph	370 0.61	370 0.61	370 0.61
Fuel consumption 50% load	g/kWh lb/hph	242 0.40	244 0.40	242 0.40
Fuel consumption 75% load	g/kWh lb/hph	223 0.37	223 0.37	223 0.37
Fuel consumption 100% load	g/kWh lb/hph	219 0.36	219 0.36	219 0.36

Inlet & exhaust data		F3L 912	F4L 912	F6L 912
max. intake depression	mbar psi	10 0.15	10 0.15	10 0.15
Combustion air volume	m ³ /h cfm	157 92	209 123	315 185
max. exhaust gas temperature	°C °F	500 932	500 932	500 932
Exhaust gas flow	m ³ /h cfm	426 251	572 337	853 502

- 1) According to ISO 8528-5.
- 2) Continuous Power: No time limitation, plus 10% additional power for governing purpose only.
- 3) Prime Power: Average power output ≤ 80%, no time limitation, plus 5% additional power for governing purpose only.
- 4) Limited Time Running Power: For up to 500 h/year, thereof a maximum of 300 h/year continuous running.
- 5) In consideration of a generator efficiency level of 89 - 90 % and a power factor of 0.8.
- 6) Refers to diesel with a density of 0.835 kg/dm³ at 15°C | 6.96 lb/US gallon at 60°F.

The data on this data sheet are for information purposes only and are not binding values. The data in the quotation is definitive.

Dimensions

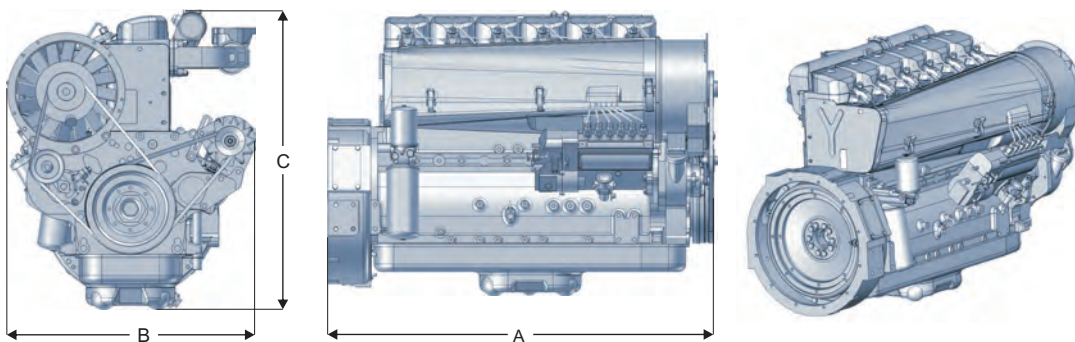

		A	B	C
F3L 912	mm in	670 26	705 28	765 30
F4L 912	mm in	775 31	705 28	765 30
F5L 912	mm in	915 36	705 28	805 32
F6L 912	mm in	1055 42	705 28	775 31

Note: The engine dimensions and weights vary depending on the scope of delivery.

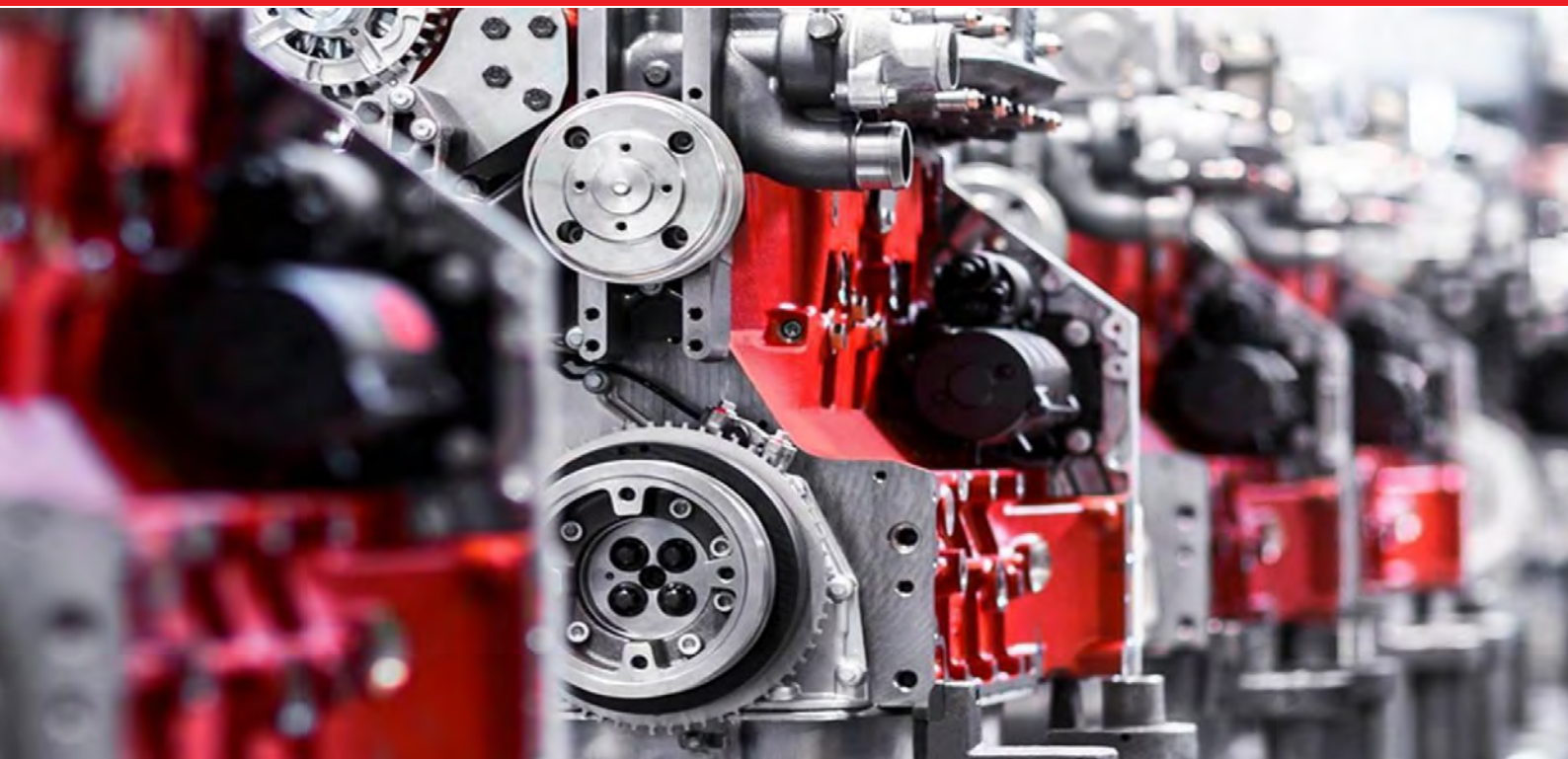

Архангельск (8182)63-90-72
Астана (7172)727-132
Астрахань (8512)99-46-04
Барнаул (3852)73-04-60
Белгород (4722)40-23-64
Брянск (4832)59-03-52
Владивосток (423)249-28-31
Волгоград (844)278-03-48
Вологда (8172)26-41-59
Воронеж (473)204-51-73
Екатеринбург (343)384-55-89
Иваново (4932)77-34-06

Ижевск (3412)26-03-58
Иркутск (395)279-98-46
Казань (843)206-01-48
Калининград (4012)72-03-81
Калуга (4842)92-23-67
Кемерово (3842)65-04-62
Киров (8332)68-02-04
Краснодар (861)203-40-90
Красноярск (391)204-63-61
Курск (4712)77-13-04
Липецк (4742)52-20-81

Магнитогорск (3519)55-03-13
Москва (495)268-04-70
Мурманск (8152)59-64-93
Набережные Челны (8552)20-53-41
Нижний Новгород (831)429-08-12
Новокузнецк (3843)20-46-81
Новосибирск (383)227-86-73
Омск (3812)21-46-40
Орел (4862)44-53-42
Оренбург (3532)37-68-04
Пенза (8412)22-31-16

Пермь (342)205-81-47
Ростов-на-Дону (863)308-18-15
Рязань (4912)46-61-64
Самара (846)206-03-16
Санкт-Петербург (812)309-46-40
Саратов (845)249-38-78
Севастополь (8692)22-31-93
Симферополь (3652)67-13-56
Смоленск (4812)29-41-54
Сочи (862)225-72-31
Ставрополь (8652)20-65-13

Сургут (3462)77-98-35
Тверь (4822)63-31-35
Томск (3822)98-41-53
Тула (4872)74-02-29
Тюмень (3452)66-21-18
Ульяновск (8422)24-23-59
Уфа (347)229-48-12
Хабаровск (4212)92-98-04
Челябинск (351)202-03-61
Череповец (8202)49-02-64
Ярославль (4852)69-52-93

Киргизия (996)312-96-26-47

Россия (495)268-04-70

Казахстан (772)734-952-31

<https://deutz.nt-rt.ru> || dze@nt-rt.ru