

# СУДОВЫЕ ДВИГАТЕЛИ СЕРИИ FL 912



Архангельск (8182)63-90-72  
Астана (7172)727-132  
Астрахань (8512)99-46-04  
Барнаул (3852)73-04-60  
Белгород (4722)40-23-64  
Брянск (4832)59-03-52  
Владивосток (423)249-28-31  
Волгоград (844)278-03-48  
Вологда (8172)26-41-59  
Воронеж (473)204-51-73  
Екатеринбург (343)384-55-89  
Иваново (4932)77-34-06

Ижевск (3412)26-03-58  
Иркутск (395)279-98-46  
Казань (843)206-01-48  
Калининград (4012)72-03-81  
Калуга (4842)92-23-67  
Кемерово (3842)65-04-62  
Киров (8332)68-02-04  
Краснодар (861)203-40-90  
Красноярск (391)204-63-61  
Курск (4712)77-13-04  
Липецк (4742)52-20-81

Магнитогорск (3519)55-03-13  
Москва (495)268-04-70  
Мурманск (8152)59-64-93  
Набережные Челны (8552)20-53-41  
Нижний Новгород (831)429-08-12  
Новокузнецк (3843)20-46-81  
Новосибирск (383)227-86-73  
Омск (3812)21-46-40  
Орел (4862)44-53-42  
Оренбург (3532)37-68-04  
Пенза (8412)22-31-16

Пермь (342)205-81-47  
Ростов-на-Дону (863)308-18-15  
Рязань (4912)46-61-64  
Самара (846)206-03-16  
Санкт-Петербург (812)309-46-40  
Саратов (845)249-38-78  
Севастополь (8692)22-31-93  
Симферополь (3652)67-13-56  
Смоленск (4812)29-41-54  
Сочи (862)225-72-31  
Ставрополь (8652)20-65-13

Сургут (3462)77-98-35  
Тверь (4822)63-31-35  
Томск (3822)98-41-53  
Тула (4872)74-02-29  
Тюмень (3452)66-21-18  
Ульяновск (8422)24-23-59  
Уфа (347)229-48-12  
Хабаровск (4212)92-98-04  
Челябинск (351)202-03-61  
Череповец (8202)49-02-64  
Ярославль (4852)69-52-93

Киргизия (996)312-96-26-47

Россия (495)268-04-70

Казахстан (772)734-952-31

<https://deutz.nt-rt.ru> || [dze@nt-rt.ru](mailto:dze@nt-rt.ru)

# FL912

for marine applications

35 - 66 kW | 47 - 89 hp at 1500 - 2500 min<sup>-1</sup> | rpm  
emission certified & type approved

- Air-cooled 3 to 6-cylinder naturally aspirated engines in inline arrangement.
- The very compact engine design and the flexibility of the positioning of the unit reduce the installation costs.
- Low fuel consumption, low maintenance costs and long life reduce the running costs.



- Due to the air cooling, the integration of the engine into the classic engine-cooling version of marine engines is omitted. Installation of the unit onto the deck is possible.
- The robust engine design allows worldwide operation even with high sulphur fuels.

## Technical data

Engine type		F3L 912	F4L 912	F5L 912	F6L 912
No. of cylinders		3	4	5	6
Bore/stroke	mm   in	102/132   4.02/5.20	102/132   4.02/5.20	102/132   4.02/5.20	102/132   4.02/5.20
Displacement	l   cu in	3.23   197.1	4.31   263.0	5.35   326.5	6.47   394.8
Compression ratio		17:1	17:1	17:1	17:1
Nominal speeds propulsion engines	min <sup>-1</sup>   rpm	1500 - 2500	1500 - 2500	1500 - 2500	1500 - 2500
Nominal speeds auxiliary engines	min <sup>-1</sup>   rpm	1500 - 1800	1500 - 1800	1500 - 1800	1500 - 1800
Specific fuel consumption <sup>1)</sup>	g/kWh   lb/hph	215   0.35	215   0.35	215   0.35	215   0.35

Power output <sup>2)</sup>			F3L 912	F4L 912	F5L 912	F6L 912
Propulsion engines	- LG A	kW   hp	35   47	46   62	58   78	70   94
	- LG B	kW   hp	38   51	51   68	65   87	78   105
Auxiliary engines	- LG G 50 Hz	kW   hp	27   36	35   47	44   59	53   71
	60 Hz	kW   hp	31   42	42   56	52   70	63   84
	- LG N 50 Hz	kW   hp	28   38	37   50	47   63	55   74
	60 Hz	kW   hp	32   43	44   59	54   72	66   89

- LG A:** Unlimited continuous operation with unlimited workload.  
**LG B:** Limited continuous operation: max. 3000 oh p.a.<sup>3)</sup>  
 Operating time with more than 90% of maximum power: max. 1500 oh p.a. Admissible workload: max. 70% of rated power.  
**LG G:** Unlimited continuous operation with unlimited workload.  
**LG N:** Unlimited continuous operation with limited workload.  
 Operating time with more than 90% of maximum power: max. 6000 oh p.a. Admissible workload: max. 80% of rated power.

- 1) Best full load consumption refers to diesel with a density of 0.835 kg/dm<sup>3</sup> at 15°C | 6.96 lb/US gallon at 60°F.  
 2) Capacity data in accordance with ISO 3046-1.  
 Further ratings on request.  
 3) oh p.a.: Operating hours per year

The data on this data sheet are for information purposes only and are not binding values. The data in the quotation is definitive.

# Torque curve

**Power group A** **Power group B**  
 2300 min<sup>-1</sup>rpm 2500 min<sup>-1</sup>rpm  
 F3L 912 | F4L 912 | F5L 912 | F6L 912 F3L 912 | F4L 912 | F5L 912 | F6L 912

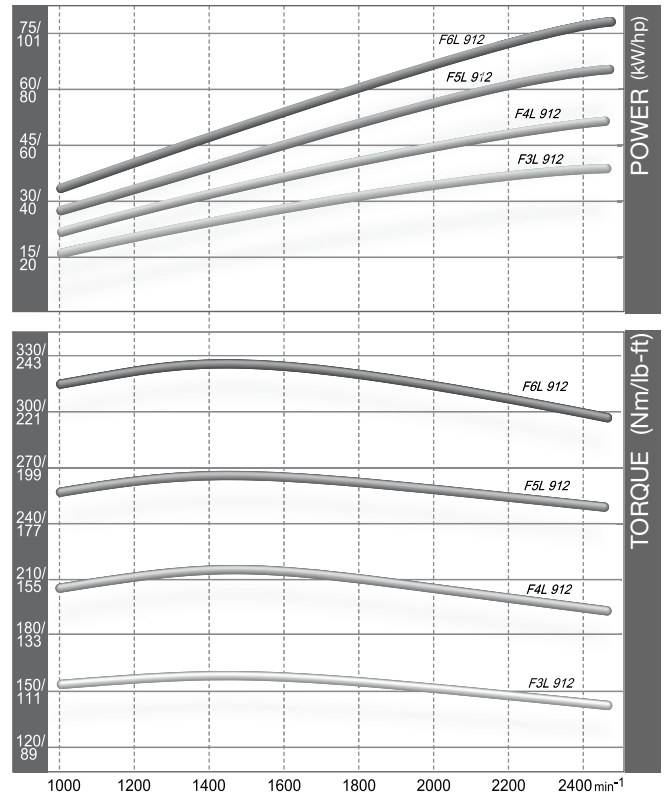
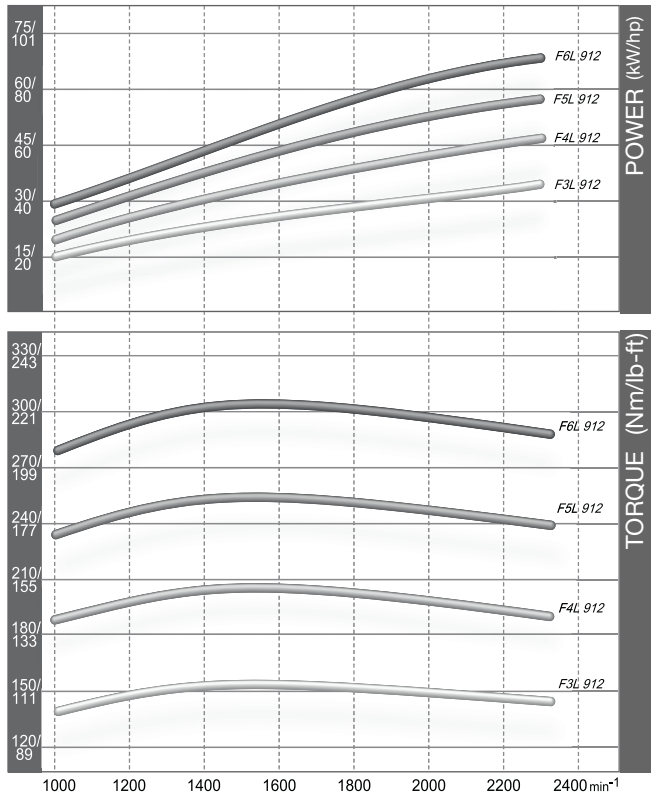

## Dimensions

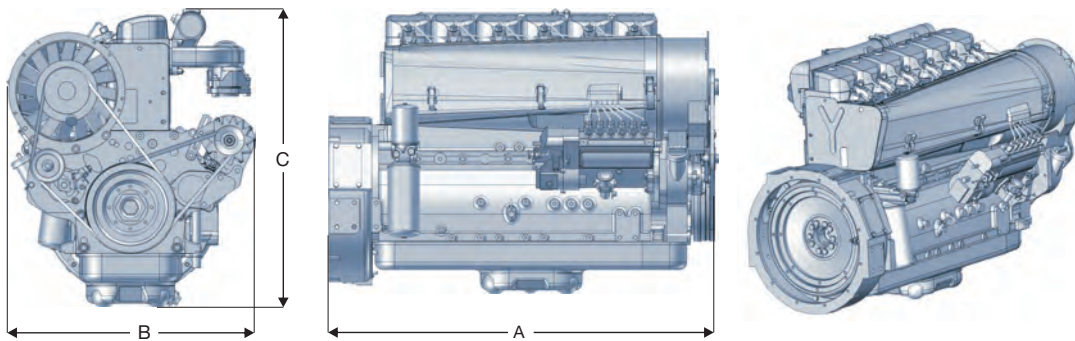

			A		B		C		Weight	
F3L 912	mm	in	691	27	680	27	800	31	270 kg	595 lb
F4L 912	mm	in	837	33	680	27	800	31	300 kg	661 lb
F5L 912	mm	in	946	37	680	27	838	33	380 kg	838 lb
F6L 912	mm	in	1094	43	680	27	811	32	410 kg	904 lb

Note: The engine dimensions and weights vary depending on the scope of delivery.

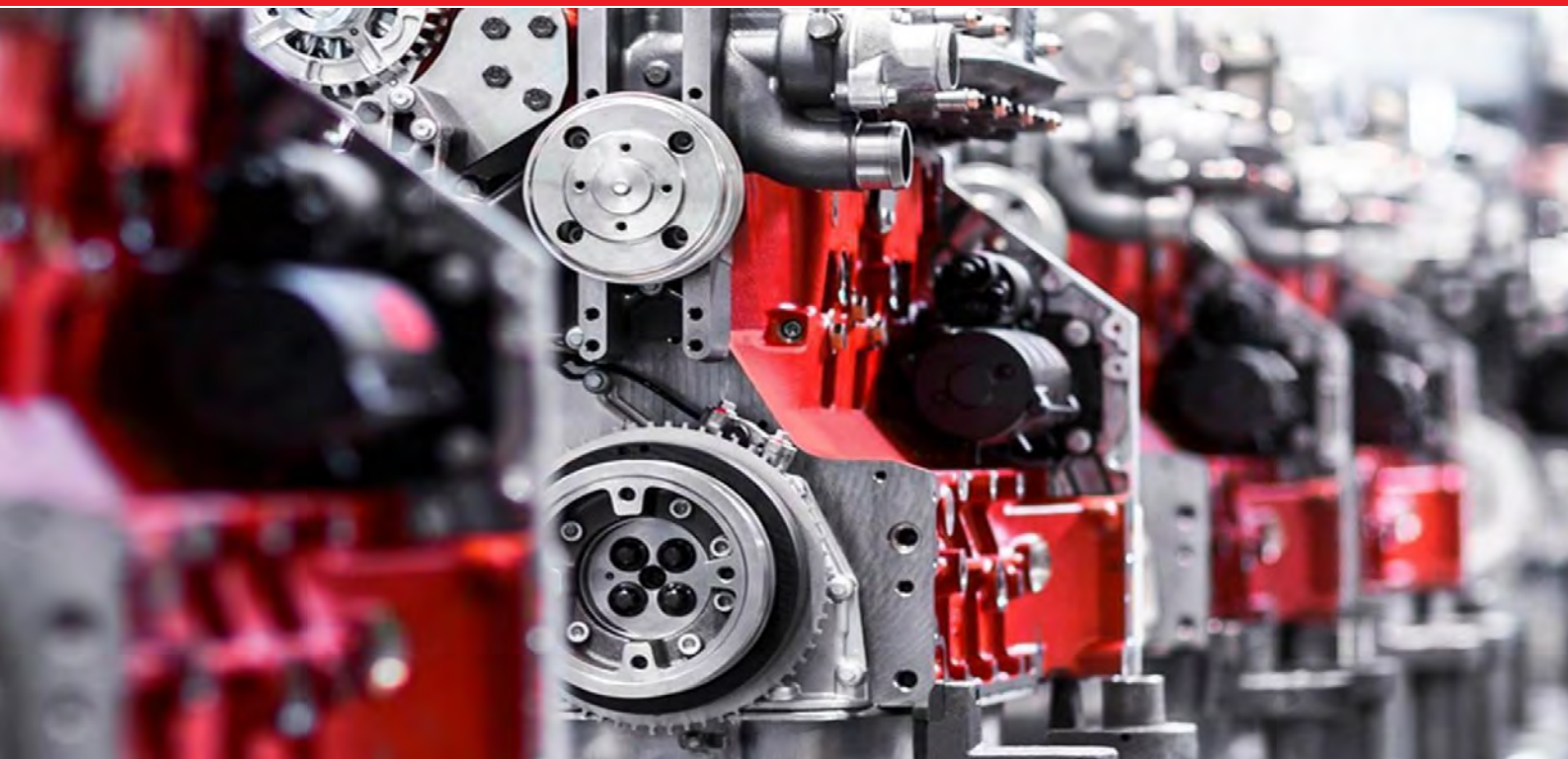

Архангельск (8182)63-90-72  
Астана (7172)727-132  
Астрахань (8512)99-46-04  
Барнаул (3852)73-04-60  
Белгород (4722)40-23-64  
Брянск (4832)59-03-52  
Владивосток (423)249-28-31  
Волгоград (844)278-03-48  
Вологда (8172)26-41-59  
Воронеж (473)204-51-73  
Екатеринбург (343)384-55-89  
Иваново (4932)77-34-06

Ижевск (3412)26-03-58  
Иркутск (395)279-98-46  
Казань (843)206-01-48  
Калининград (4012)72-03-81  
Калуга (4842)92-23-67  
Кемерово (3842)65-04-62  
Киров (8332)68-02-04  
Краснодар (861)203-40-90  
Красноярск (391)204-63-61  
Курск (4712)77-13-04  
Липецк (4742)52-20-81

Магнитогорск (3519)55-03-13  
Москва (495)268-04-70  
Мурманск (8152)59-64-93  
Набережные Челны (8552)20-53-41  
Нижний Новгород (831)429-08-12  
Новокузнецк (3843)20-46-81  
Новосибирск (383)227-86-73  
Омск (3812)21-46-40  
Орел (4862)44-53-42  
Оренбург (3532)37-68-04  
Пенза (8412)22-31-16

Пермь (342)205-81-47  
Ростов-на-Дону (863)308-18-15  
Рязань (4912)46-61-64  
Самара (846)206-03-16  
Санкт-Петербург (812)309-46-40  
Саратов (845)249-38-78  
Севастополь (8692)22-31-93  
Симферополь (3652)67-13-56  
Смоленск (4812)29-41-54  
Сочи (862)225-72-31  
Ставрополь (8652)20-65-13

Сургут (3462)77-98-35  
Тверь (4822)63-31-35  
Томск (3822)98-41-53  
Тула (4872)74-02-29  
Тюмень (3452)66-21-18  
Ульяновск (8422)24-23-59  
Уфа (347)229-48-12  
Хабаровск (4212)92-98-04  
Челябинск (351)202-03-61  
Череповец (8202)49-02-64  
Ярославль (4852)69-52-93

Киргизия (996)312-96-26-47

Россия (495)268-04-70

Казахстан (772)734-952-31

<https://deutz.nt-rt.ru> || [dze@nt-rt.ru](mailto:dze@nt-rt.ru)