

# ДВИГАТЕЛИ ДЛЯ АЭРОПОРТНОЙ ТЕХНИКИ СЕРИИ BFM 2012

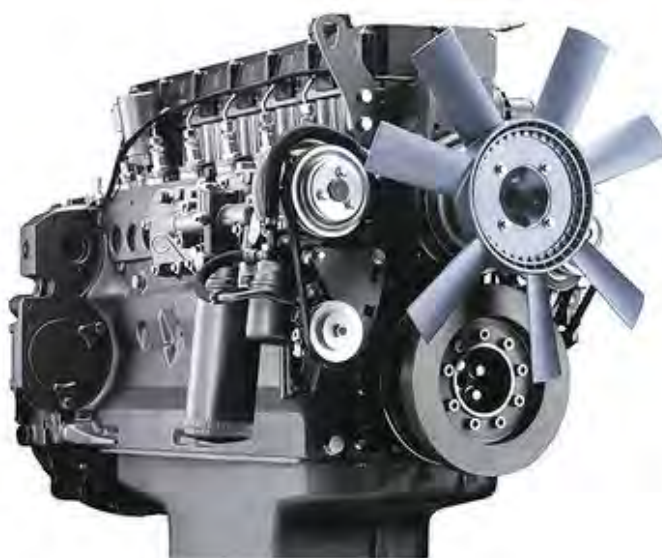

Архангельск (8182)63-90-72  
Астана (7172)727-132  
Астрахань (8512)99-46-04  
Барнаул (3852)73-04-60  
Белгород (4722)40-23-64  
Брянск (4832)59-03-52  
Владивосток (423)249-28-31  
Волгоград (844)278-03-48  
Вологда (8172)26-41-59  
Воронеж (473)204-51-73  
Екатеринбург (343)384-55-89  
Иваново (4932)77-34-06

Ижевск (3412)26-03-58  
Иркутск (395)279-98-46  
Казань (843)206-01-48  
Калининград (4012)72-03-81  
Калуга (4842)92-23-67  
Кемерово (3842)65-04-62  
Киров (8332)68-02-04  
Краснодар (861)203-40-90  
Красноярск (391)204-63-61  
Курск (4712)77-13-04  
Липецк (4742)52-20-81

Магнитогорск (3519)55-03-13  
Москва (495)268-04-70  
Мурманск (8152)59-64-93  
Набережные Челны (8552)20-53-41  
Нижний Новгород (831)429-08-12  
Новокузнецк (3843)20-46-81  
Новосибирск (383)227-86-73  
Омск (3812)21-46-40  
Орел (4862)44-53-42  
Оренбург (3532)37-68-04  
Пенза (8412)22-31-16

Пермь (342)205-81-47  
Ростов-на-Дону (863)308-18-15  
Рязань (4912)46-61-64  
Самара (846)206-03-16  
Санкт-Петербург (812)309-46-40  
Саратов (845)249-38-78  
Севастополь (8692)22-31-93  
Симферополь (3652)67-13-56  
Смоленск (4812)29-41-54  
Сочи (862)225-72-31  
Ставрополь (8652)20-65-13

Сургут (3462)77-98-35  
Тверь (4822)63-31-35  
Томск (3822)98-41-53  
Тула (4872)74-02-29  
Тюмень (3452)66-21-18  
Ульяновск (8422)24-23-59  
Уфа (347)229-48-12  
Хабаровск (4212)92-98-04  
Челябинск (351)202-03-61  
Череповец (8202)49-02-64  
Ярославль (4852)69-52-93

Киргизия (996)312-96-26-47

Россия (495)268-04-70

Казахстан (772)734-952-31

<https://deutz.nt-rt.ru> || [dze@nt-rt.ru](mailto:dze@nt-rt.ru)

# BFM 2012

For mobile machinery

74,9 - 155 kW | 100 - 208 hp at 2500 min<sup>-1</sup> | rpm

EU Stage II / US EPA Tier 2

- Water-cooled 4 and 6-cylinder inline engines with turbocharging and charge air cooling
- The compact engine design and three PTO drive possibilities integrated into the gear drive reduce the installation costs and offer numerous application possibilities.
- Long oil change intervals and easy changing of the engine fluids reduce the running costs and increase the availability of the machinery.

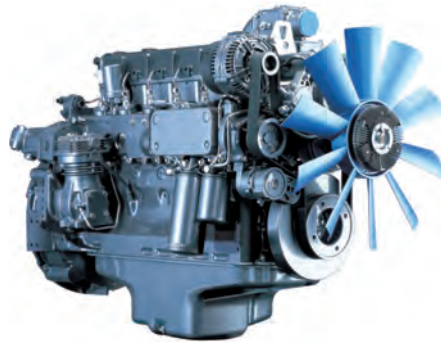

- Best cold starting performance even under extreme conditions.

- Also available with an electronic motor regulator (EMR) to allow easy integration into the electronic device control and monitoring system.
- Low noise emissions due to acoustically optimized components with very smooth running and high durability.
- The robust engine design allows worldwide operation even with high sulphur fuels.
- The engines meet the requirements of the EU Stage II and US EPA Tier 2.

## Technical data

Engine type		BF4M 2012	BF4M 2012C	BF6M 2012C
No. of cylinders		4	4	6
Bore/stroke	mm   in	101 / 126   4.0 / 5.0	101 / 126   4.0 / 5.0	101 / 126   4.0 / 5.0
Displacement	l   cu in	4.04   247	4.04   247	6.06   370
Max. nominal speed	min <sup>-1</sup>   rpm	2500	2500	2500

Engine type		BF4M 2012	BF4M 2012C	BF6M 2012C
Power output as per ISO 14396 <sup>1)</sup>	kW   hp	74.9   100	103   138	155   208
at speed	min <sup>-1</sup>   rpm	2500	2500	2500
Max. torque	Nm   lb/ft	390   288	493   364	743   548
at speed	min <sup>-1</sup>   rpm	1500	1500	1500
Minimum idling speed	min <sup>-1</sup>   rpm	800	800	800
Specific fuel consumption <sup>2)</sup>	g/kWh   lb/hph	208   0.34	202   0.33	202   0.33
Weight as per DIN 70020 Part 7A <sup>3)</sup>	kg   lb	391   862	391   862	509   1122

1) Power data without deduction of fan power.

2) Best point consumption refers to diesel with a density of 0.835 kg/dm<sup>3</sup> at 15°C.

3) Without starter/alternator, cooler and fluids but with flywheel and flywheel housing.

The data on this data sheet are for information purposes only and are not binding values. The data in the quotation is definitive.

## Torque curve

BF4M 2012 - 74,9 kW|100 hp  
 BF4M 2012C - 103 kW|138 hp

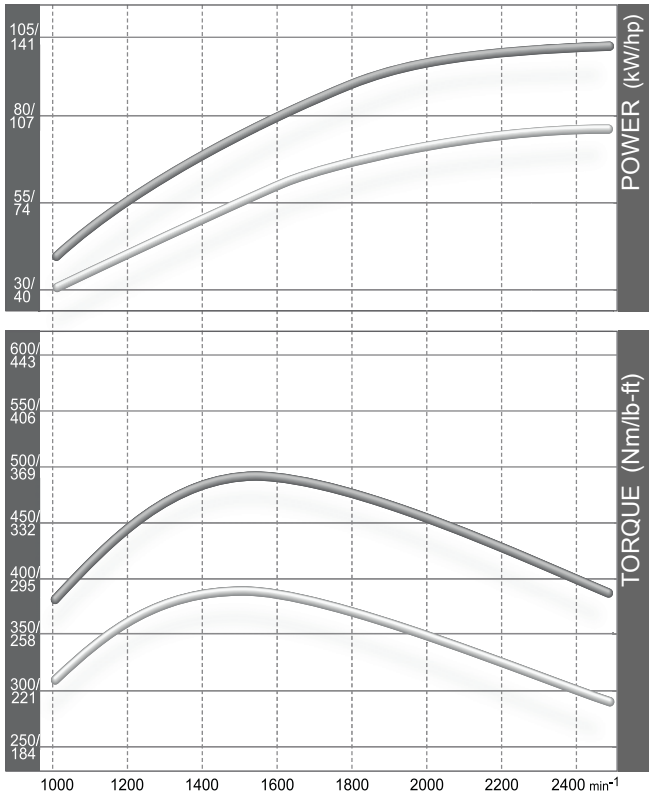

BF6M 2012C - 155 kW|208 hp

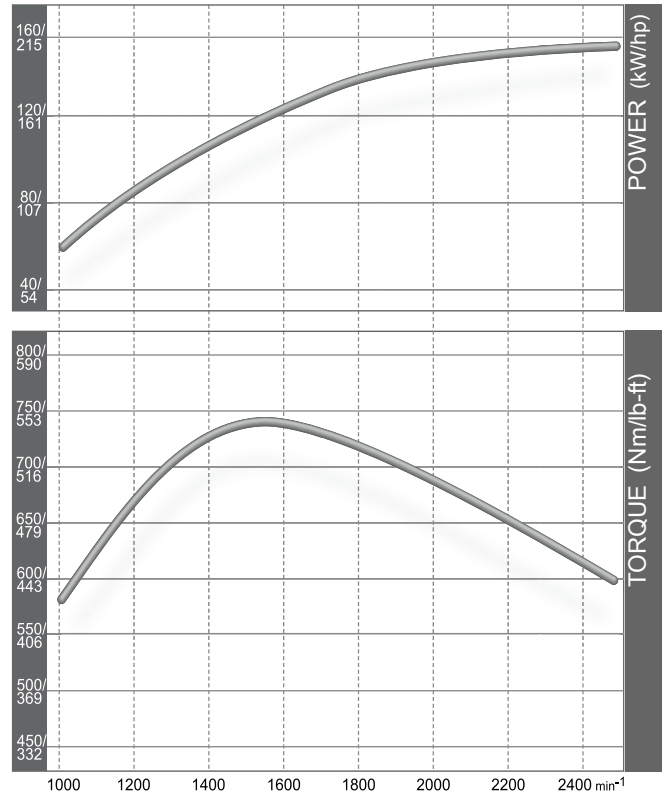

## Dimensions

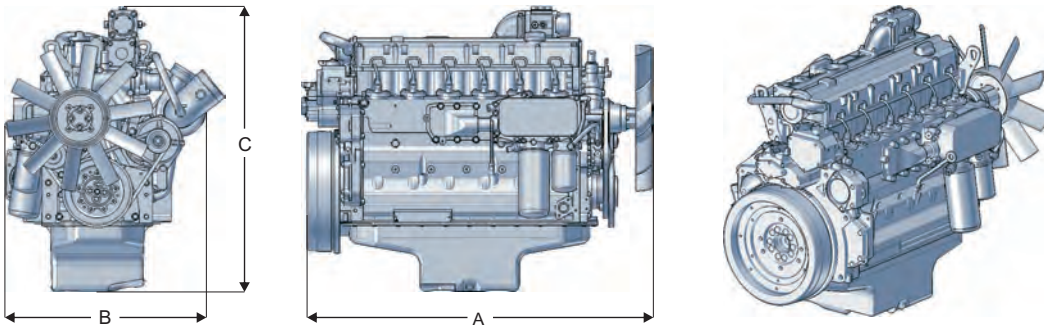

		A*	A**	B	C
BF4M 2012	mm   in	847   33.3	903   35.6	643   25.3	741   29.2
BF4M 2012C	mm   in	847   33.3	903   35.6	643   25.3	835   32.9
BF6M 2012	mm   in	1003   39.5	1120   44.1	628   24.7	920   36.2

\* V-belt drive

\*\* Poly-V belt drive

Note: The engine dimensions and weights vary depending on the scope of delivery.

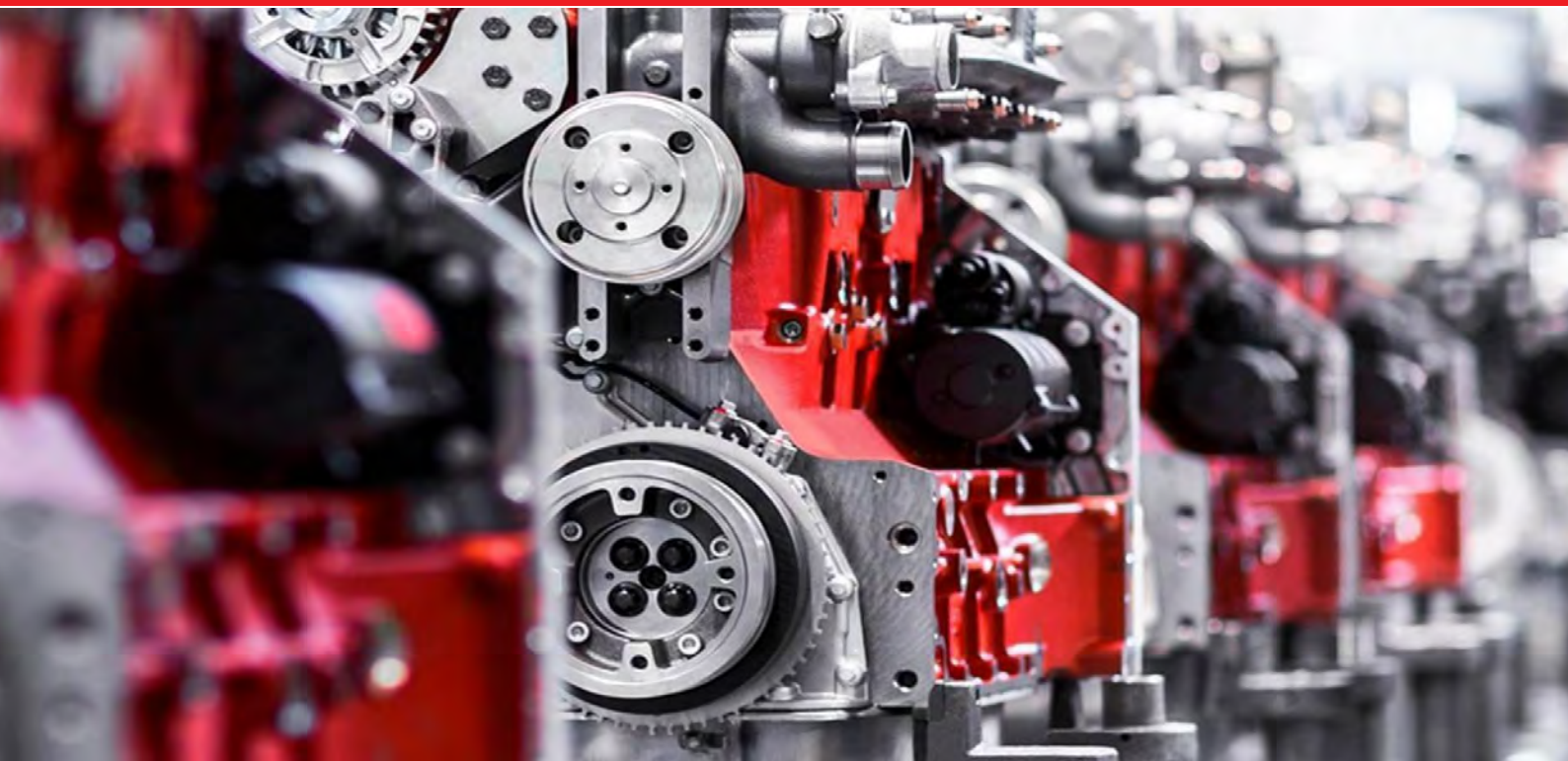

Архангельск (8182)63-90-72  
Астана (7172)727-132  
Астрахань (8512)99-46-04  
Барнаул (3852)73-04-60  
Белгород (4722)40-23-64  
Брянск (4832)59-03-52  
Владивосток (423)249-28-31  
Волгоград (844)278-03-48  
Вологда (8172)26-41-59  
Воронеж (473)204-51-73  
Екатеринбург (343)384-55-89  
Иваново (4932)77-34-06

Ижевск (3412)26-03-58  
Иркутск (395)279-98-46  
Казань (843)206-01-48  
Калининград (4012)72-03-81  
Калуга (4842)92-23-67  
Кемерово (3842)65-04-62  
Киров (8332)68-02-04  
Краснодар (861)203-40-90  
Красноярск (391)204-63-61  
Курск (4712)77-13-04  
Липецк (4742)52-20-81

Магнитогорск (3519)55-03-13  
Москва (495)268-04-70  
Мурманск (8152)59-64-93  
Набережные Челны (8552)20-53-41  
Нижний Новгород (831)429-08-12  
Новокузнецк (3843)20-46-81  
Новосибирск (383)227-86-73  
Омск (3812)21-46-40  
Орел (4862)44-53-42  
Оренбург (3532)37-68-04  
Пенза (8412)22-31-16

Пермь (342)205-81-47  
Ростов-на-Дону (863)308-18-15  
Рязань (4912)46-61-64  
Самара (846)206-03-16  
Санкт-Петербург (812)309-46-40  
Саратов (845)249-38-78  
Севастополь (8692)22-31-93  
Симферополь (3652)67-13-56  
Смоленск (4812)29-41-54  
Сочи (862)225-72-31  
Ставрополь (8652)20-65-13

Сургут (3462)77-98-35  
Тверь (4822)63-31-35  
Томск (3822)98-41-53  
Тула (4872)74-02-29  
Тюмень (3452)66-21-18  
Ульяновск (8422)24-23-59  
Уфа (347)229-48-12  
Хабаровск (4212)92-98-04  
Челябинск (351)202-03-61  
Череповец (8202)49-02-64  
Ярославль (4852)69-52-93

Киргизия (996)312-96-26-47

Россия (495)268-04-70

Казахстан (772)734-952-31

<https://deutz.nt-rt.ru> || [dze@nt-rt.ru](mailto:dze@nt-rt.ru)