

ДВИГАТЕЛИ ДЛЯ СТРОИТЕЛЬНОЙ ТЕХНИКИ СЕРИИ VFM 1013



Архангельск (8182)63-90-72
Астана (7172)727-132
Астрахань (8512)99-46-04
Барнаул (3852)73-04-60
Белгород (4722)40-23-64
Брянск (4832)59-03-52
Владивосток (423)249-28-31
Волгоград (844)278-03-48
Вологда (8172)26-41-59
Воронеж (473)204-51-73
Екатеринбург (343)384-55-89
Иваново (4932)77-34-06

Ижевск (3412)26-03-58
Иркутск (395)279-98-46
Казань (843)206-01-48
Калининград (4012)72-03-81
Калуга (4842)92-23-67
Кемерово (3842)65-04-62
Киров (8332)68-02-04
Краснодар (861)203-40-90
Красноярск (391)204-63-61
Курск (4712)77-13-04
Липецк (4742)52-20-81

Магнитогорск (3519)55-03-13
Москва (495)268-04-70
Мурманск (8152)59-64-93
Набережные Челны (8552)20-53-41
Нижний Новгород (831)429-08-12
Новокузнецк (3843)20-46-81
Новосибирск (383)227-86-73
Омск (3812)21-46-40
Орел (4862)44-53-42
Оренбург (3532)37-68-04
Пенза (8412)22-31-16

Пермь (342)205-81-47
Ростов-на-Дону (863)308-18-15
Рязань (4912)46-61-64
Самара (846)206-03-16
Санкт-Петербург (812)309-46-40
Саратов (845)249-38-78
Севастополь (8692)22-31-93
Симферополь (3652)67-13-56
Смоленск (4812)29-41-54
Сочи (862)225-72-31
Ставрополь (8652)20-65-13

Сургут (3462)77-98-35
Тверь (4822)63-31-35
Томск (3822)98-41-53
Тула (4872)74-02-29
Тюмень (3452)66-21-18
Ульяновск (8422)24-23-59
Уфа (347)229-48-12
Хабаровск (4212)92-98-04
Челябинск (351)202-03-61
Череповец (8202)49-02-64
Ярославль (4852)69-52-93

Киргизия (996)312-96-26-47

Россия (495)268-04-70

Казахстан (772)734-952-31

<https://deutz.nt-rt.ru> || dze@nt-rt.ru

DEUTZ BFM 1013

For mobile machinery ■ 92 - 223 kW | 123 - 299 hp at 2000 - 2300 min⁻¹ | rpm ■ EU stage II / US EPA Tier 2

- Water-cooled 4 and 6-cylinder inline engines with turbocharging and charge air cooling
- The robust engine design allows worldwide operation even with high sulphur fuels.
- The compact engine design and three PTO drive possibilities integrated into the gear drive reduce the installation cost and increase the number of applications.
- Best cold starting performance even under extreme conditions.
- Low noise emissions due to acoustically optimized components with very smooth running and high durability.
- Wet cylinder liners, long oil change intervals and easy changing of the engine fluids reduce the running and service cost and increase the availability of the machinery.
- Also available with an electronic motor regulator (EMR) to allow easy integration into the electronic device control and monitoring system.

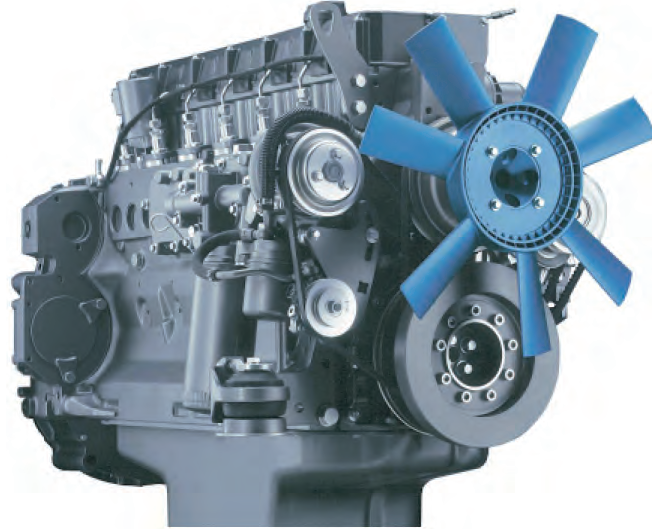

TECHNICAL DATA

Engine Type		BF4M1013EC	BF4M1013FC	BF6M1013EC	BF6M1013FC
No. of cylinders		4	4	6	6
Bore/stroke	mm in	108/130 4.3/5.1	108/130 4.3/5.1	108/130 4.3/5.1	108/130 4.3/5.1
Displacement	l cu in	4.8 292.9	4.8 292.9	7.2 439.4	7.2 439.4
Maximum nominal speed	min ⁻¹ rpm	2300	2300	2300	2300

Engine Type		BF4M1013EC	BF4M1013FC	BF6M1013EC	BF6M1013FC
Power output as per ISO 14396	kW hp	118 158	118 158	174 233	200/223 ⁴⁾ 268/299
at speed	min ⁻¹ rpm	2300	2300	2300	2300
Max. torque	Nm lb/ft	577 426	700 516	854 630	1050 774
at speed	min ⁻¹ rpm	1400	1400	1400	1400
Minimum idling speed	min ⁻¹ rpm	650	650	650	650
Specific fuel consumption ²⁾	g/kWh lb/hph	205 0.337	204 0.335	205 0.337	195 0.321
Weight as per DIN 70020 Part 7A ³⁾	kg lb	432 952	432 952	572 1261	572 1261

1) Power data without deduction of fan power.

2) Best full load consumption refers to diesel with a density of 0.835 kg/dm³ at 15°C | 6.96 lb/US gallon at 60°F.

3) Without starter/alternator, cooler and fluids but with flywheel and flywheel housing.

4) Exceptional output.

CHARACTERISTIC CURVES

BF4M 1013 EC - 118 kW
BF4M 1013 FC - 129 kW

BF6M 1013 EC - 174 kW
BF6M 1013 FC - 200 kW / BF6M 1013 FC - 223 kW

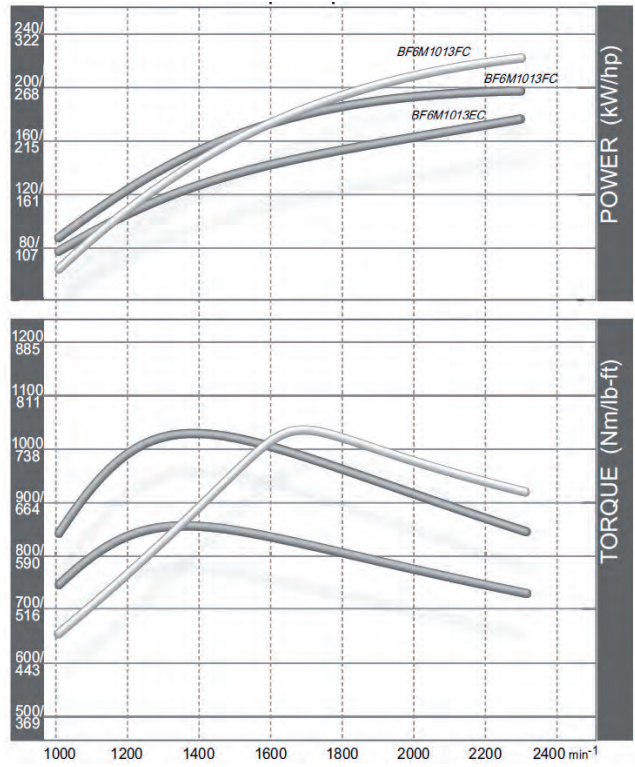
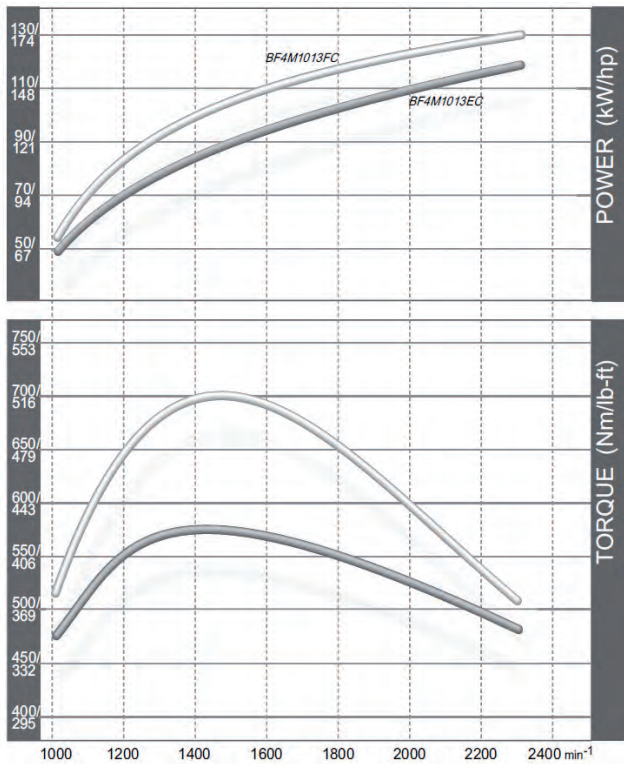

DIMENSIONS

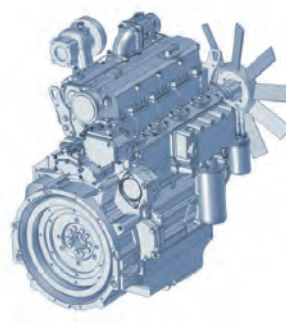
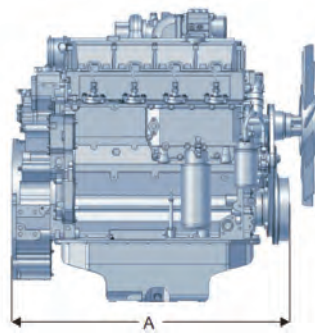
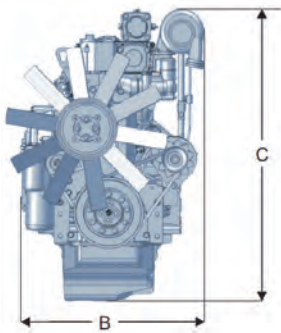

Engine Type		A	B	C
BF4M 1013 EC / FC	mm in	895 35.2	634 25	940 37
BF6M 1013 EC / FC	mm in	1162 45.7	683 26.9	990 39

Note: Preliminary technical data. The engine dimensions and weights vary depending on the scope of delivery.

The data on this data sheet are for information purposes only and are not binding values. For more information please contact your responsible sales partner.

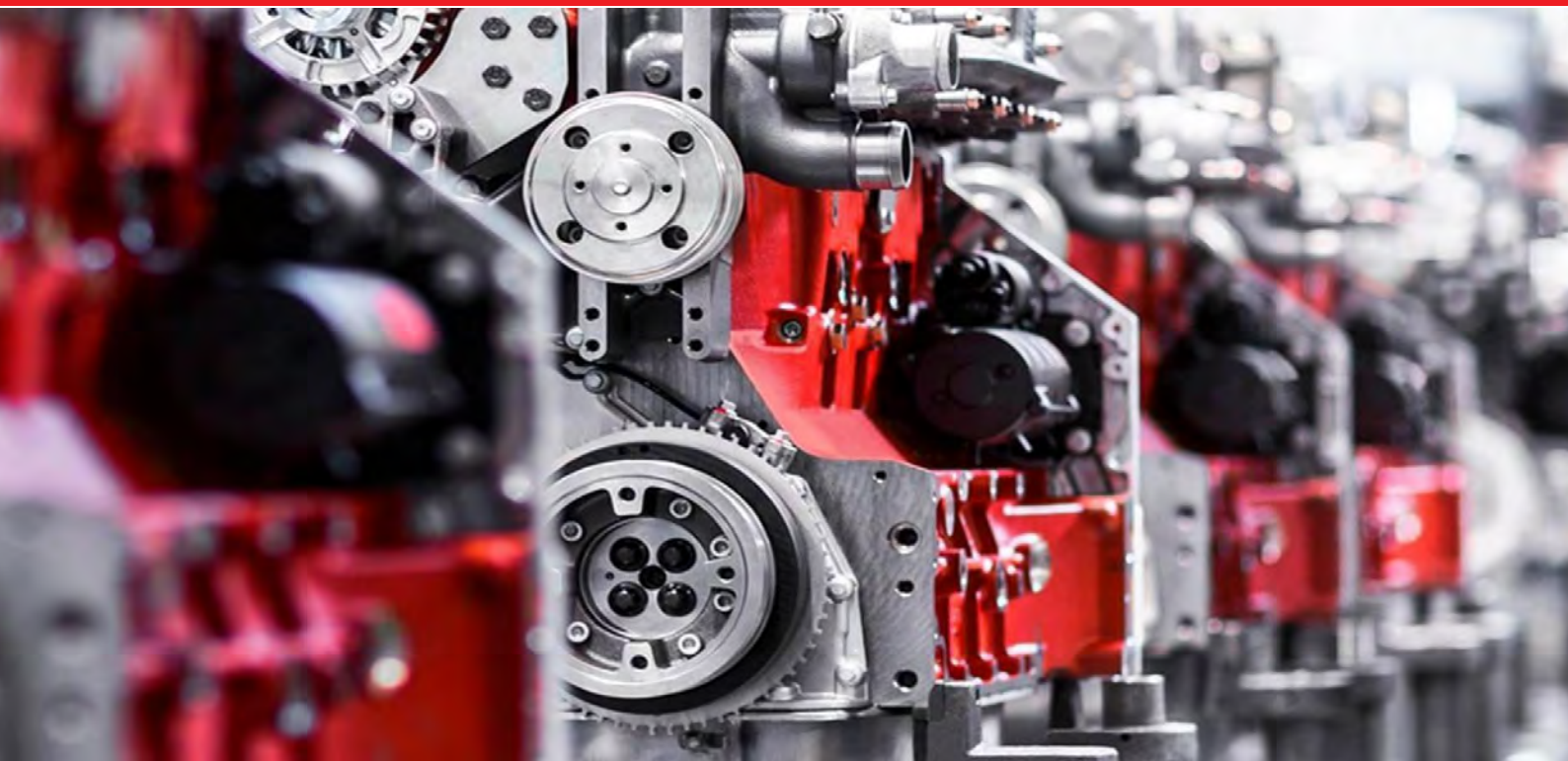

Архангельск (8182)63-90-72
Астана (7172)727-132
Астрахань (8512)99-46-04
Барнаул (3852)73-04-60
Белгород (4722)40-23-64
Брянск (4832)59-03-52
Владивосток (423)249-28-31
Волгоград (844)278-03-48
Вологда (8172)26-41-59
Воронеж (473)204-51-73
Екатеринбург (343)384-55-89
Иваново (4932)77-34-06

Ижевск (3412)26-03-58
Иркутск (395)279-98-46
Казань (843)206-01-48
Калининград (4012)72-03-81
Калуга (4842)92-23-67
Кемерово (3842)65-04-62
Киров (8332)68-02-04
Краснодар (861)203-40-90
Красноярск (391)204-63-61
Курск (4712)77-13-04
Липецк (4742)52-20-81

Магнитогорск (3519)55-03-13
Москва (495)268-04-70
Мурманск (8152)59-64-93
Набережные Челны (8552)20-53-41
Нижний Новгород (831)429-08-12
Новокузнецк (3843)20-46-81
Новосибирск (383)227-86-73
Омск (3812)21-46-40
Орел (4862)44-53-42
Оренбург (3532)37-68-04
Пенза (8412)22-31-16

Пермь (342)205-81-47
Ростов-на-Дону (863)308-18-15
Рязань (4912)46-61-64
Самара (846)206-03-16
Санкт-Петербург (812)309-46-40
Саратов (845)249-38-78
Севастополь (8692)22-31-93
Симферополь (3652)67-13-56
Смоленск (4812)29-41-54
Сочи (862)225-72-31
Ставрополь (8652)20-65-13

Сургут (3462)77-98-35
Тверь (4822)63-31-35
Томск (3822)98-41-53
Тула (4872)74-02-29
Тюмень (3452)66-21-18
Ульяновск (8422)24-23-59
Уфа (347)229-48-12
Хабаровск (4212)92-98-04
Челябинск (351)202-03-61
Череповец (8202)49-02-64
Ярославль (4852)69-52-93

Киргизия (996)312-96-26-47

Россия (495)268-04-70

Казахстан (772)734-952-31

<https://deutz.nt-rt.ru> || dze@nt-rt.ru