

ДВИГАТЕЛИ ДЛЯ АГРОТЕХНИКИ СЕРИИ BFM 1013



Архангельск (8182)63-90-72
Астана (7172)727-132
Астрахань (8512)99-46-04
Барнаул (3852)73-04-60
Белгород (4722)40-23-64
Брянск (4832)59-03-52
Владивосток (423)249-28-31
Волгоград (844)278-03-48
Вологда (8172)26-41-59
Воронеж (473)204-51-73
Екатеринбург (343)384-55-89
Иваново (4932)77-34-06

Ижевск (3412)26-03-58
Иркутск (395)279-98-46
Казань (843)206-01-48
Калининград (4012)72-03-81
Калуга (4842)92-23-67
Кемерово (3842)65-04-62
Киров (8332)68-02-04
Краснодар (861)203-40-90
Красноярск (391)204-63-61
Курск (4712)77-13-04
Липецк (4742)52-20-81

Магнитогорск (3519)55-03-13
Москва (495)268-04-70
Мурманск (8152)59-64-93
Набережные Челны (8552)20-53-41
Нижний Новгород (831)429-08-12
Новокузнецк (3843)20-46-81
Новосибирск (383)227-86-73
Омск (3812)21-46-40
Орел (4862)44-53-42
Оренбург (3532)37-68-04
Пенза (8412)22-31-16

Пермь (342)205-81-47
Ростов-на-Дону (863)308-18-15
Рязань (4912)46-61-64
Самара (846)206-03-16
Санкт-Петербург (812)309-46-40
Саратов (845)249-38-78
Севастополь (8692)22-31-93
Симферополь (3652)67-13-56
Смоленск (4812)29-41-54
Сочи (862)225-72-31
Ставрополь (8652)20-65-13

Сургут (3462)77-98-35
Тверь (4822)63-31-35
Томск (3822)98-41-53
Тула (4872)74-02-29
Тюмень (3452)66-21-18
Ульяновск (8422)24-23-59
Уфа (347)229-48-12
Хабаровск (4212)92-98-04
Челябинск (351)202-03-61
Череповец (8202)49-02-64
Ярославль (4852)69-52-93

Киргизия (996)312-96-26-47

Россия (495)268-04-70

Казахстан (772)734-952-31

<https://deutz.nt-rt.ru> || dze@nt-rt.ru

BFM 1013

For agricultural machinery

137 - 165 kW | 184 - 221 hp at 2300 min⁻¹ | rpm

EU Stage II / US EPA Tier 2

- Water-cooled 4 and 6-cylinder inline engines with turbocharging and charge air cooling
- The extremely compact engine design with structural oil pan and a customer-oriented, modular system of optional add-on parts reduce the installation costs and increase the number of applications.
- Also available with an electronic motor regulator (EMR) to allow easy integration into the electronic device control and monitoring system.

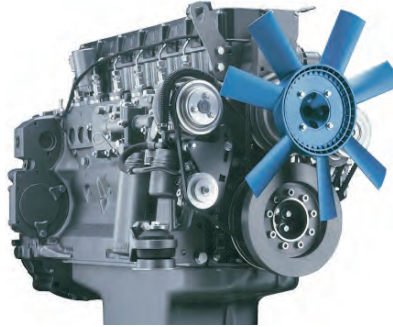

- Best cold starting performance even under extreme conditions.

- Low noise emissions due to acoustically optimized components with very smooth running and high durability.
- 100% power take-off at flywheel and front end.
- Wet cylinder liners, long oil change intervals and easy changing of the engine fluids reduce the running costs and increase the availability of the machinery.
- The engines meet the requirements of the EU Stage II and US EPA Tier 2.

Technical data

Engine type		BF6M1013E	BF6M1013EC
No. of cylinders		6	6
Bore/stroke	mm in	108 / 130 4.3 / 5.1	108 / 130 4.3 / 5.1
Displacement	l cu in	7.2 436	7.2 436
Max. nominal speed	min ⁻¹ rpm	2300	2300

Engine type		BF6M1013E	BF6M1013EC
Power output as per ISO 14396 ¹⁾	kW hp	137 184	165 221
at speed	min ⁻¹ rpm	2300	2300
Max. torque	Nm lb/ft	702 518	854 630
at speed	min ⁻¹ rpm	1400	1400
Minimum idling speed	min ⁻¹ rpm	800	800
Specific fuel consumption ²⁾	g/kWh lb/hph	208 0.34	208 0.34
Weight as per DIN 70020 Part 7A ³⁾	kg lb	570 1257	572 1261

1) Power data without deduction of fan power.

2) Best point consumption refers to diesel with a density of 0.835 kg/dm³ at 15°C.

3) Without starter/alternator, cooler and fluids but with flywheel and flywheel housing.

The data on this data sheet are for information purposes only and are not binding values. The data in the quotation is definitive.

Torque curve

BF6M 1013E - 137 kW|184 hp

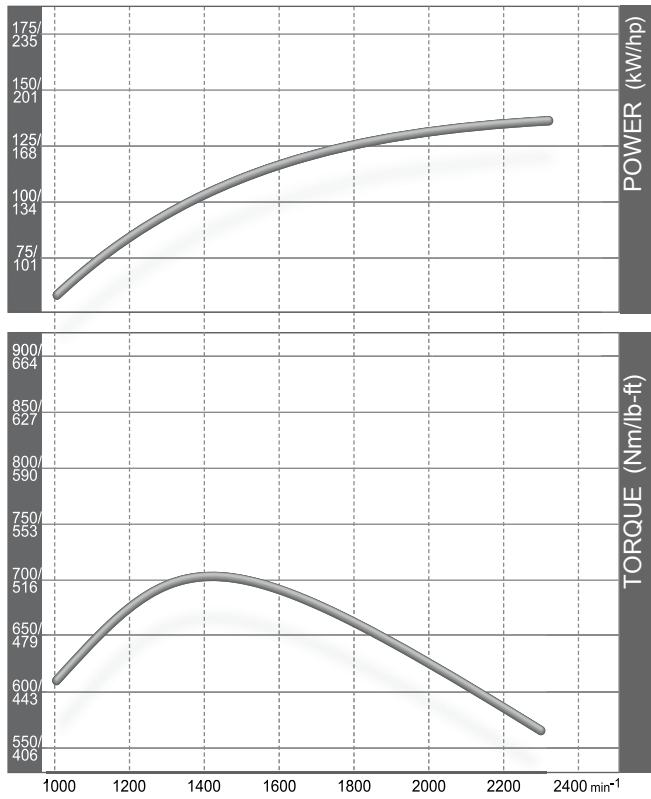

BF6M 1013EC - 165 kW|221 hp

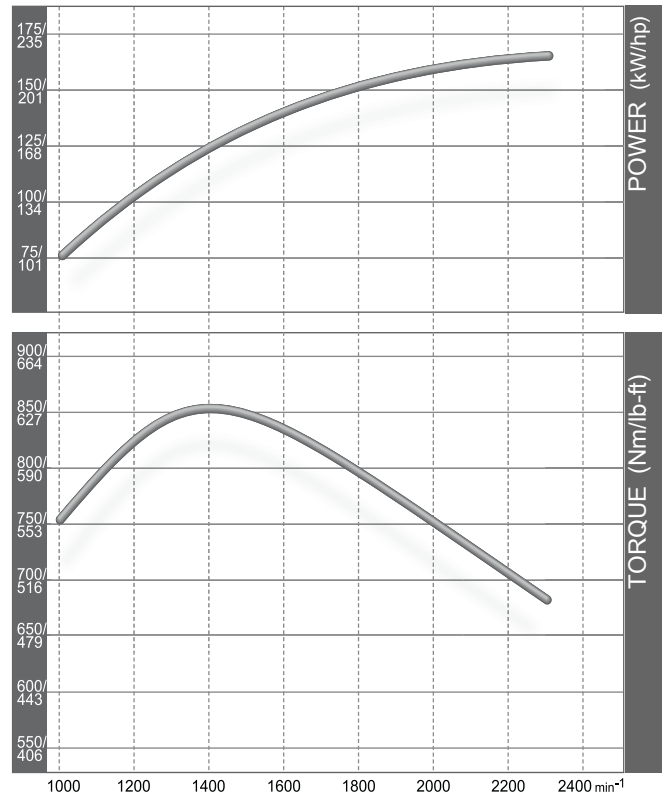

Dimensions

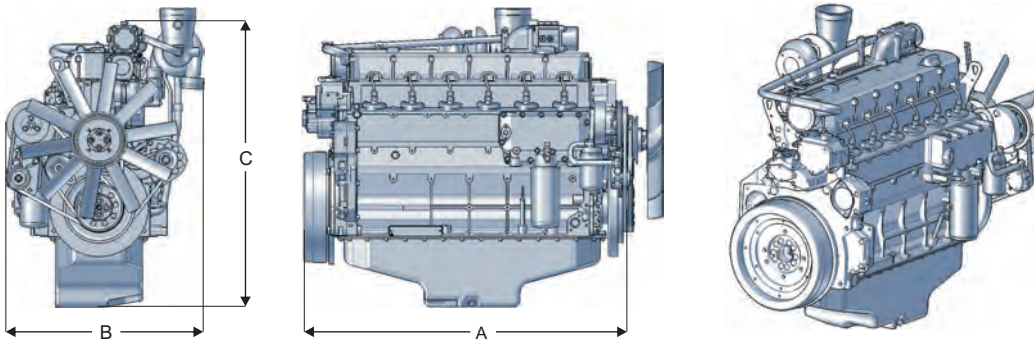

		A	B	C
BF6M1013E/EC	mm in	1177 46.3	574 22.6	1001 39.4

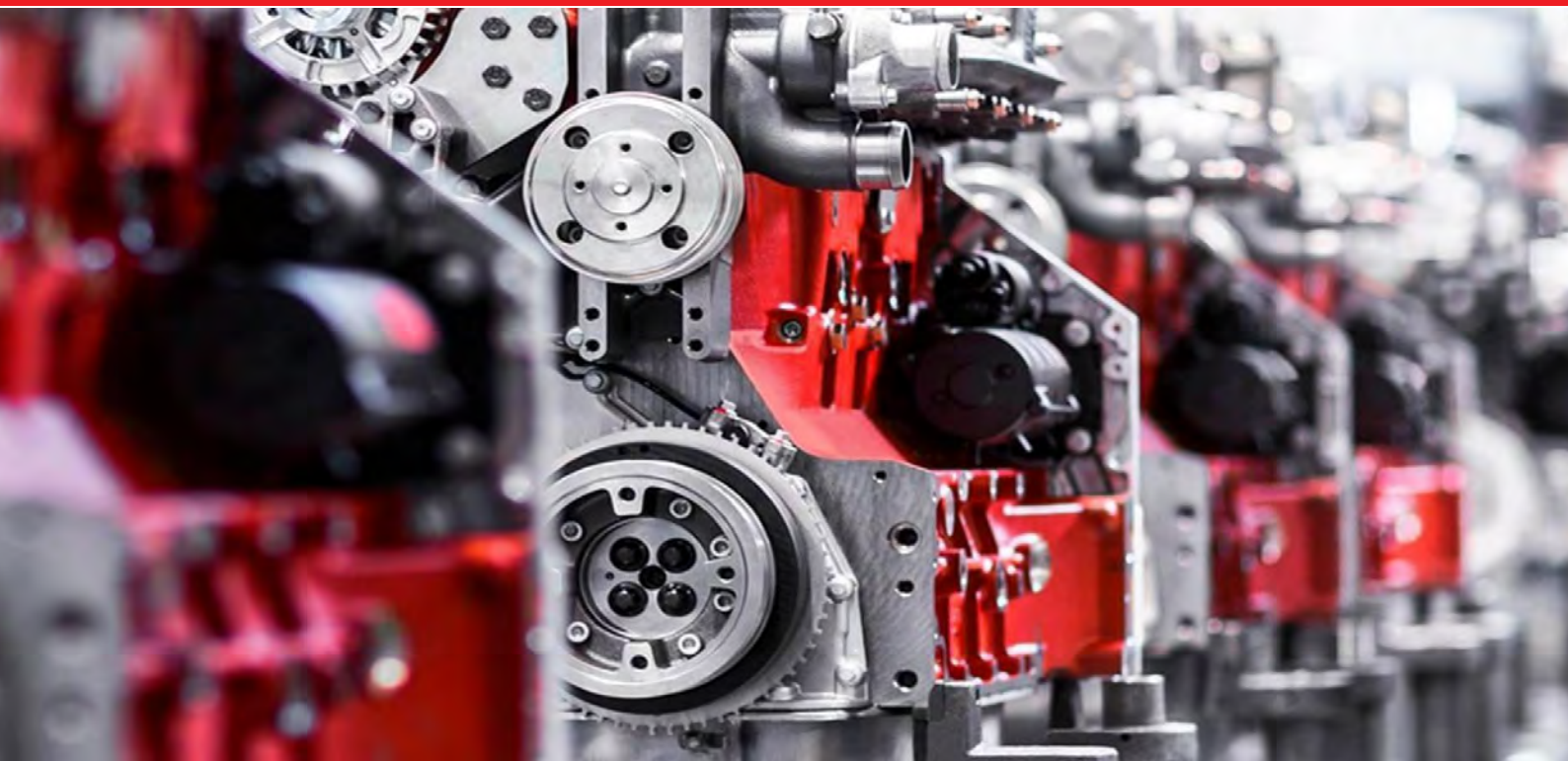

Архангельск (8182)63-90-72
Астана (7172)727-132
Астрахань (8512)99-46-04
Барнаул (3852)73-04-60
Белгород (4722)40-23-64
Брянск (4832)59-03-52
Владивосток (423)249-28-31
Волгоград (844)278-03-48
Вологда (8172)26-41-59
Воронеж (473)204-51-73
Екатеринбург (343)384-55-89
Иваново (4932)77-34-06

Ижевск (3412)26-03-58
Иркутск (395)279-98-46
Казань (843)206-01-48
Калининград (4012)72-03-81
Калуга (4842)92-23-67
Кемерово (3842)65-04-62
Киров (8332)68-02-04
Краснодар (861)203-40-90
Красноярск (391)204-63-61
Курск (4712)77-13-04
Липецк (4742)52-20-81

Магнитогорск (3519)55-03-13
Москва (495)268-04-70
Мурманск (8152)59-64-93
Набережные Челны (8552)20-53-41
Нижний Новгород (831)429-08-12
Новокузнецк (3843)20-46-81
Новосибирск (383)227-86-73
Омск (3812)21-46-40
Орел (4862)44-53-42
Оренбург (3532)37-68-04
Пенза (8412)22-31-16

Пермь (342)205-81-47
Ростов-на-Дону (863)308-18-15
Рязань (4912)46-61-64
Самара (846)206-03-16
Санкт-Петербург (812)309-46-40
Саратов (845)249-38-78
Севастополь (8692)22-31-93
Симферополь (3652)67-13-56
Смоленск (4812)29-41-54
Сочи (862)225-72-31
Ставрополь (8652)20-65-13

Сургут (3462)77-98-35
Тверь (4822)63-31-35
Томск (3822)98-41-53
Тула (4872)74-02-29
Тюмень (3452)66-21-18
Ульяновск (8422)24-23-59
Уфа (347)229-48-12
Хабаровск (4212)92-98-04
Челябинск (351)202-03-61
Череповец (8202)49-02-64
Ярославль (4852)69-52-93

Киргизия (996)312-96-26-47

Россия (495)268-04-70

Казахстан (772)734-952-31

<https://deutz.nt-rt.ru> || dze@nt-rt.ru