

# ДВИГАТЕЛИ ДЛЯ СТРОИТЕЛЬНОЙ ТЕХНИКИ СЕРИИ BFL 2011



Архангельск (8182)63-90-72  
Астана (7172)727-132  
Астрахань (8512)99-46-04  
Барнаул (3852)73-04-60  
Белгород (4722)40-23-64  
Брянск (4832)59-03-52  
Владивосток (423)249-28-31  
Волгоград (844)278-03-48  
Вологда (8172)26-41-59  
Воронеж (473)204-51-73  
Екатеринбург (343)384-55-89  
Иваново (4932)77-34-06

Ижевск (3412)26-03-58  
Иркутск (395)279-98-46  
Казань (843)206-01-48  
Калининград (4012)72-03-81  
Калуга (4842)92-23-67  
Кемерово (3842)65-04-62  
Киров (8332)68-02-04  
Краснодар (861)203-40-90  
Красноярск (391)204-63-61  
Курск (4712)77-13-04  
Липецк (4742)52-20-81

Киргизия (996)312-96-26-47

Магнитогорск (3519)55-03-13  
Москва (495)268-04-70  
Мурманск (8152)59-64-93  
Набережные Челны (8552)20-53-41  
Нижний Новгород (831)429-08-12  
Новокузнецк (3843)20-46-81  
Новосибирск (383)227-86-73  
Омск (3812)21-46-40  
Орел (4862)44-53-42  
Оренбург (3532)37-68-04  
Пенза (8412)22-31-16

Россия (495)268-04-70

Пермь (342)205-81-47  
Ростов-на-Дону (863)308-18-15  
Рязань (4912)46-61-64  
Самара (846)206-03-16  
Санкт-Петербург (812)309-46-40  
Саратов (845)249-38-78  
Севастополь (8692)22-31-93  
Симферополь (3652)67-13-56  
Смоленск (4812)29-41-54  
Сочи (862)225-72-31  
Ставрополь (8652)20-65-13

Казахстан (772)734-952-31

Сургут (3462)77-98-35  
Тверь (4822)63-31-35  
Томск (3822)98-41-53  
Тула (4872)74-02-29  
Тюмень (3452)66-21-18  
Ульяновск (8422)24-23-59  
Уфа (347)229-48-12  
Хабаровск (4212)92-98-04  
Челябинск (351)202-03-61  
Череповец (8202)49-02-64  
Ярославль (4852)69-52-93

<https://deutz.nt-rt.ru> || [dze@nt-rt.ru](mailto:dze@nt-rt.ru)

# BFL 2011

For mobile machinery

23 - 58.1 kW | 30.8 - 77.9 hp at 2800 min<sup>-1</sup> | rpm

EU Stage II / US EPA Tier 2

- Oil-cooled 2, 3 and 4-cylinder aspirated engine in inline construction with integrated cooling system.
- 4-cylinder also with turbocharging.
- Direct injection with single injection pumps and optional electronic governor.
- High reliability combined with durability. No corrosion or cavitation due to oil cooling and lubrication.

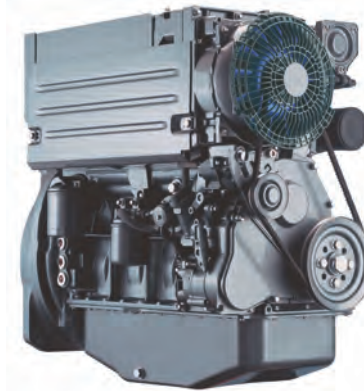

- Best cold starting performance even under extreme conditions.
- Minimised running costs due to low maintenance need and little wear.
- Low fuel consumption due to optimised combustion.
- Long oil change intervals of up to 1000 hours.
- The robust engine design allows worldwide operation even with high sulphur fuels.

## Technical data

Engine type		F2L 2011	F3L 2011	F4L 2011	BF4L 2011
No. of cylinders		2	3	4	4
Bore/stroke	mm   in	94 / 112   3.7/4.4	94 / 112   3.7/4.4	94 / 112   3.7/4.4	94 / 112   3.7/4.4
Displacement	l   cu in	1.6   95	2.3   142	3.1   190	3.1   190
Max. nominal speed	min <sup>-1</sup>   rpm	2800	2800	2800	2800

Engine type		F2L 2011	F3L 2011	F4L 2011	BF4L 2011
Power output as per ISO 14396 <sup>1)</sup>	kW   hp	23   30.8	35.8   48.0	47.8   64.1	58.1   77.9
at speed	min <sup>-1</sup>   rpm	2800	2800	2800	2800
Max. torque	Nm   lb/ft	90   66.4	137   101.0	190   140.1	230   169.6
at speed	min <sup>-1</sup>   rpm	1700	1700	1700	1600
Minimum idling speed	min <sup>-1</sup>   rpm	900	900	900	900
Specific fuel consumption <sup>2)</sup>	g/kWh   lb/hph	220   0.36	218   0.36	214   0.35	205   0.34
Weight as per DIN 70020 Part 7A <sup>3)</sup>	kg   lb	175   385.8	216   476.2	254   560.0	255   562.2

1) Power data without deduction of fan power.

2) Best point consumption refers to diesel with a density of 0.835 kg/dm<sup>3</sup> at 15°C.

3) Without starter/alternator, cooler and fluids but with flywheel and flywheel housing.

The data on this data sheet are for information purposes only and are not binding values. The data in the quotation is definitive.

## Torque curve

F2L 2011 - 23 kW|30.8 hp

F3L 2011 - 35.8 kW|48.0 hp

F4L 2011 - 47.8 kW|64.1 hp

BF4L 2011 - 58.1 kW|77.9 hp

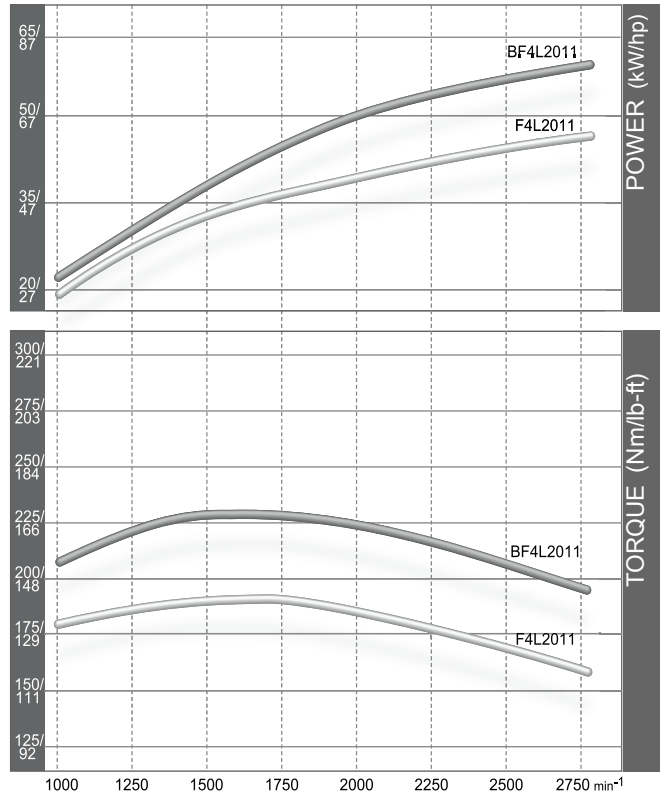
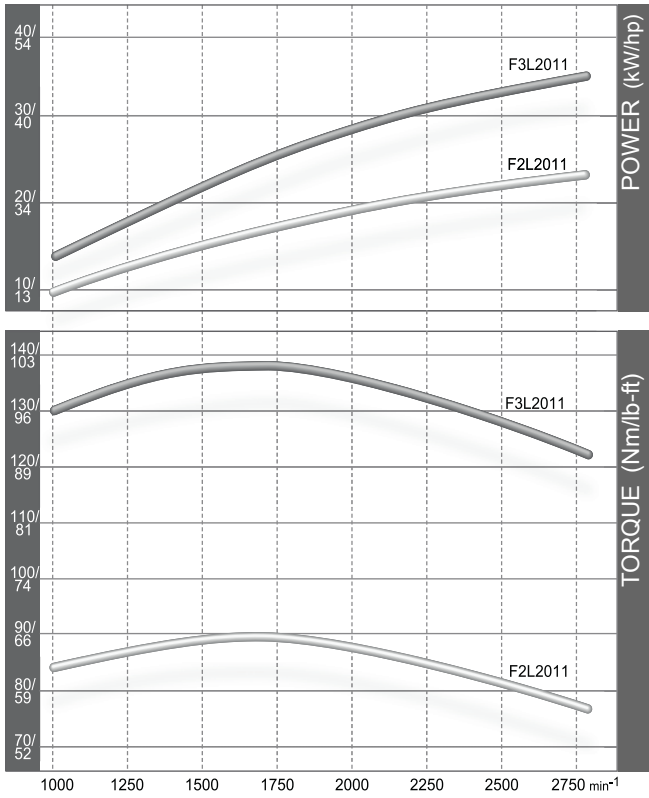

## Dimensions

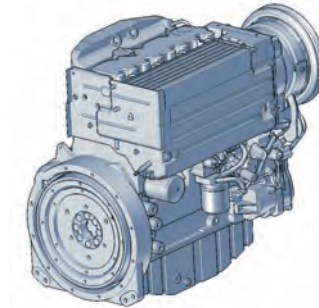
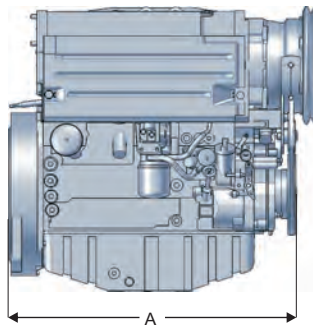
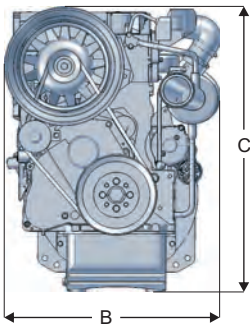

		A	B	C
F2L 2011	mm   in	487   19.2	451   17.8	683   26.9
F3L 2011	mm   in	599   23.6	451   17.8	678   26.7
F4L 2011	mm   in	710   28.0	451   17.8	703   27.7
BF4L 2011	mm   in	710   28.0	495   19.5	703   27.7

Note: The engine dimensions and weights vary depending on the scope of delivery.

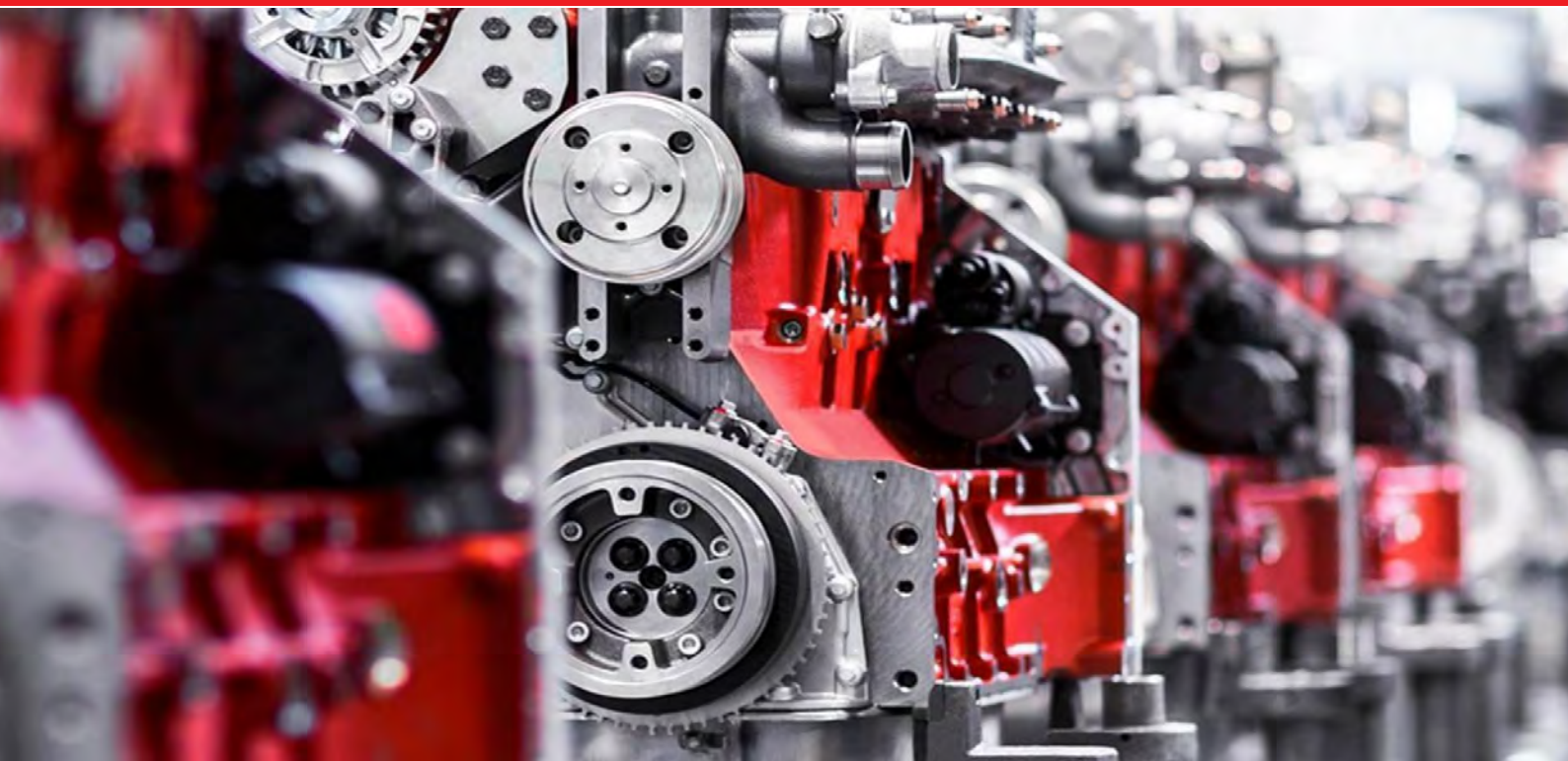

Архангельск (8182)63-90-72  
Астана (7172)727-132  
Астрахань (8512)99-46-04  
Барнаул (3852)73-04-60  
Белгород (4722)40-23-64  
Брянск (4832)59-03-52  
Владивосток (423)249-28-31  
Волгоград (844)278-03-48  
Вологда (8172)26-41-59  
Воронеж (473)204-51-73  
Екатеринбург (343)384-55-89  
Иваново (4932)77-34-06

Ижевск (3412)26-03-58  
Иркутск (395)279-98-46  
Казань (843)206-01-48  
Калининград (4012)72-03-81  
Калуга (4842)92-23-67  
Кемерово (3842)65-04-62  
Киров (8332)68-02-04  
Краснодар (861)203-40-90  
Красноярск (391)204-63-61  
Курск (4712)77-13-04  
Липецк (4742)52-20-81

Магнитогорск (3519)55-03-13  
Москва (495)268-04-70  
Мурманск (8152)59-64-93  
Набережные Челны (8552)20-53-41  
Нижний Новгород (831)429-08-12  
Новокузнецк (3843)20-46-81  
Новосибирск (383)227-86-73  
Омск (3812)21-46-40  
Орел (4862)44-53-42  
Оренбург (3532)37-68-04  
Пенза (8412)22-31-16

Пермь (342)205-81-47  
Ростов-на-Дону (863)308-18-15  
Рязань (4912)46-61-64  
Самара (846)206-03-16  
Санкт-Петербург (812)309-46-40  
Саратов (845)249-38-78  
Севастополь (8692)22-31-93  
Симферополь (3652)67-13-56  
Смоленск (4812)29-41-54  
Сочи (862)225-72-31  
Ставрополь (8652)20-65-13

Сургут (3462)77-98-35  
Тверь (4822)63-31-35  
Томск (3822)98-41-53  
Тула (4872)74-02-29  
Тюмень (3452)66-21-18  
Ульяновск (8422)24-23-59  
Уфа (347)229-48-12  
Хабаровск (4212)92-98-04  
Челябинск (351)202-03-61  
Череповец (8202)49-02-64  
Ярославль (4852)69-52-93

Киргизия (996)312-96-26-47

Россия (495)268-04-70

Казахстан (772)734-952-31

<https://deutz.nt-rt.ru> || [dze@nt-rt.ru](mailto:dze@nt-rt.ru)